



*ISMRM 20th Annual
Meeting & Exhibition*

5 – 11 May, 2012

Table of Contents

I General Show Information

- Deadline Checklist
- Security
- Insurance Requirement
- Exhibitor Appointed Contractor

II Marketing Opportunities

- Sponsorship & Marketing Opportunities
- Company Profile for Guide to the Exhibition

III Ancillary Meetings

- Ancillary Meetings & Exhibitor Functions
- Exhibitor Function Space Request

IV Registration

- Exhibitor Registration Form
- Waived Scientific Meetings Vouchers
- Exhibitor Guest Vouchers

V Harry the Hirer – Booth Services & Decoration

- General Information
- Terms & Conditions
- Schell Scheme Package
- Schell Scheme Sign Confirmation
- Furniture Order Form & Stand Layout
- Lighting & Power Order Form & Stand Layout
- Rigging Order Form
- Exhibitor Banner Information

VI Mendelssohn Event Logistics

- Shipping Instructions & Information
- Customs & Transportation Services Order Form
- Shipment Order Form
- Fumigation Release Form
- Advance Warehouse Order Form

VII Ancillary Services

- Audio Visual – NES Electronic Hire
- Janitorial / Stand Cleaning – IKON Services
- Melbourne Convention & Exhibition Center
 - Contents
 - Service Information
 - Service Order Forms

*ISMRRM 20th Annual
Meeting & Exhibition*

5 – 11 May, 2012



I General Show Information

- Deadline Checklist
- Security
- Insurance Requirement
- Exhibitor Appointed Contractor



melbourne
A U S T R A L I A

2012 Exhibitor

Deadline Check List

*Forms are to be received by the appropriate service supplier no later than the corresponding dates listed below. Forms must be returned to the address listed on the form. * Required*

<u>Deadline</u>	<u>Service</u>	<u>Completed</u>
2 December 2011	Receipt of Exhibitor Contracts*	
2 December 2011	All Booth Space Must Be Paid in Full*	
13 February 2012	Company Profile for the ISMRM Guide to the Exhibition*	
17 February 2012	Reserve advertising space in the Exhibition Guide	
17 February 2012	Advertisement for insertion in the Exhibition Guide	
17 February 2012	Exhibitor Meetings Request Form	
24 February 2012	Exhibitor Certificate of Insurance*	
9 March 2012	Exhibitor Guest Voucher Order Form*	
9 March 2012	Exhibitor Pre-registration Form for Badges*	
26 March 2012	Exhibitor Appointed Contractor Forms	
2 April 2012	Exhibitor Hotel Reservations *	
2 April 2012	Water/Gas/Air Installations Order Form	
2 April 2012	Booth Catering Menu	
6 April 2012	Internet Access: Hardwire or Wireless	
13 April 2012	Telecommunications - Telephone/Telefax	
20 April 2012	Electric Installations Order Form	
20 April 2012	Exhibitor Audio/Visual/Computer equipment Order Form	
REFER TO FORMS	Harry the Hirer Booth Services Order Forms*	
REFER TO FORM	Mendelsson Event Logistics Shipping Service Information	



2012 Exhibitor

Security

The International Society for Magnetic Resonance in Medicine will provide one security guard at the entrance of the exhibit hall on a 24-hour basis and an additional roving guard during closed hours only throughout the exhibition, as well as during set-up and dismantle times.

If individual security needs are required for an exhibitor's booth, the exhibitor should contact the ISMRM or view the additional order form provided within this Service Kit for additional pricing information. The ISMRM is not responsible for any loss of or damage to any property, for any cause.

Due to the integration of traditional and e-posters onto the exhibition floor, there may be a greater need to contract additional security to your booth. Please make note of the liability and insurance policies on page 21 of the ISMRM Prospectus for requirements.

Please make sure that additional security measures are in place for booths that include valuable displays during off hours on the exhibition floor.

Technical Exhibition Dates & Hours

17:45–19:15 Sunday, 6 May (Opening Reception)
09:30–16:30 Monday–Wednesday, 7–9 May
09:00–16:30 Thursday, 10 May

Poster Viewing Hours

07:00–14:00 Sunday, 6 May (Poster Installation)
07:00–20:30 Monday, 7 May (Viewing)
07:00–19:45 Tuesday, 8 May (Viewing)
07:00–21:30 Wednesday, 9 May (Viewing)
07:00–16:30 Thursday, 10 May (Viewing); 16:30–18:00 (Dismantle)

Admission

By badge only

Restrictions

Children under 16 are not allowed on the exhibit floor

For further information regarding special security arrangements, contact:

Sandra Daudlin
ISMRM Director of Meetings
Email: sandra@ismrm.org
Phone: +1(510) 841-1899



elbourne
A U S T R A L I A

2012 Exhibitor

Insurance Requirement

Each exhibitor must make provisions for safeguarding its goods, materials, equipment, and display at all times. General overall guard service will be provided by ISMRM for the exhibition period, but neither the guard service nor ISMRM will be responsible for loss of or damage to any property for any cause. Additional security can be purchased by contacting Sandra Daudlin, ISMRM Director of Meetings, sandra@ismrm.org.

All space occupied by an exhibitor must be surrendered by it in the same condition as it was at the commencement of occupation. Each exhibitor shall defend, indemnify, and hold harmless ISMRM and each of its agents from any demands, claims, damages to persons or property, losses and liabilities, including reasonable attorney fees asserted by third parties arising out of, or connected with, exhibitor's participation in the exhibition (collectivity "claim"). This provision will not apply when a claim arises out of the sole negligence of the ISMRM.

Each exhibitor shall maintain, entirely at its expense, general public liability insurance against claims for bodily injury, death, or property damage incident to, arising out of, or in any way connected with the exhibitor's participation in the exhibition, to the limit of not less than one million US dollars (US\$1,000,000) for bodily injury, death, or property damage in any one occurrence. Such insurance maintained by the exhibitor shall include coverage of the indemnification obligations of the exhibitor under these rules and regulations and shall cover ISMRM as an additional named insured. At least 60 days prior to the start of the meeting, the exhibitor shall furnish to ISMRM a valid certificate, with the ISMRM named as an additional insured, evidencing the insurance required by these rules and regulations to be maintained by the exhibitor. That certificate, or the related policy, must provide, to the extent obtainable, that the policy may not be canceled without at least ten (10) days' prior written notice by mail to ISMRM by the insurance company. Each exhibitor acknowledges that it is responsible for obtaining, for its protection and entirely at its expense, such property insurance for its exhibit and display materials as the exhibitor deems appropriate. Any policy providing such property insurance must contain an express waiver by the exhibitor's insurance company of any right of subrogation as to any claims against ISMRM, its officers, directors, agents, or employees.

In the event any part of the exhibit hall is destroyed or damaged so as to prevent ISMRM from permitting an exhibitor to occupy assigned space during any part or the whole of the exhibition period, or in the event occupation of assigned space during any part or whole of the exhibition period is prevented by strikes, Acts of God, national emergency, or other cause beyond the control of ISMRM, then the exhibitor will be charged for the space during the period it was or could have been occupied by the exhibitor; and the exhibitor hereby waives any claim against ISMRM, its officers, directors, agents, or employees, for losses or damages which may arise in consequence of such inability to occupy assigned space, its sole claim against ISMRM being a refund of the rent paid for the period it was prevented from using the space.

Please send proof of insurance to ISMRM Meetings Coordinator Melisa Martinez at Melisa@ismrm.org by 24 February 2012.



Melbourne
A U S T R A L I A

2012 Exhibitor

Exhibitor Appointed Contractor

DEADLINE: 26 March 2012

**ISMRM 20th Annual Meeting & Exhibition
5-11 May, 2012**

Melbourne, Victoria, Australia

IF YOUR COMPANY PLANS TO USE A CONTRACTOR THAT IS NOT THE OFFICIAL DESIGNATED SHOW CONTRACTOR PLEASE COMPLETE THIS FORM AND MAIL OR FAX TO THE ISMRM MEETINGS DEPARTMENT NO LATER THAN 26 March 2012.

IMPORTANT: A certificate of Insurance, naming the ISMRM as an additional insured and valid through the dates of the ISMRM 20th Annual Meeting & Exhibition, and signed EAC Agreement must be received by the ISMRM no later than 26 March 2012 or your EAC will not be permitted to service your exhibit.

EXHIBITING COMPANY: _____ **BOOTH:** _____

APPOINTED CONTRACTOR COMPANY: _____

CONTRACTOR'S ADDRESS: _____

CONTRACTOR'S PHONE: _____

ON SITE SUPERVISOR: _____

TYPE OF SERVICE TO BE PROVIDED: _____

AUTHORIZED EXHIBITOR'S SIGNATURE: _____

AUTHORIZED EXHIBITOR'S NAME (Please Print): _____

Please send or fax this form to:

ISMRM Meetings Department
2030 Addison Street, Suite 700
Berkeley, CA 94704 USA
Tel: +1 (510) 841-1899
Fax: +1 (510) 841-2340

Attention: Melisa Martinez melisa@ismrm.org



II Marketing Opportunities

Sponsorship & Marketing Opportunities
Company Profile for Guide to the Exhibition



elbourne
A U S T R A L I A

2012 Exhibitor

Sponsorship & Marketing Opportunities

Please note, sponsoring any item for the ISMRM 20th Annual Meeting & Exhibition entitles your company to be acknowledged on the ISMRM Web sites as an official meeting sponsor.

Sponsorship of the Opening Reception with acknowledgment given throughout the venue via signage and thank you messaging on video screens. Advertising on our event drink tickets, gobo's, napkins, etc., will give your company maximum exposure to this prestigious audience.

Sponsorship of the Study Group Session Room with acknowledgment given at the dedicated study group session room via signage and thank you messaging, as well as other highly visible opportunities. ISMRM study groups are now meeting throughout the day in a dedicated session room. Be seen by these important leaders (19 study groups) in their designated meeting room as they gather many times daily to discuss focused research in the field of MRI.

Full page advertisement in the Guide to the Exhibition & Posters

This will be in the form of a thank you ad from the ISMRM and will only feature partner logos.

Acknowledgment of support

On a special Annual Meeting Signature Partner sponsorship web page for the Annual Meeting; Special signage at booth location; Group sponsorship of the Historical Archives video presentations in the lobby/registration area of the convention center, with acknowledgment through ad displays for our sponsors, promoting booth traffic, products, etc.

Advertisement in the Guide to the Exhibition & Posters

Your company's advertisement in our full color Guide to the Exhibition & Posters is distributed to over 5,500 meeting attendees. Full page and half page spaces are available. Reserve your ad space by 17 February 2012. Artwork is due by 2 March 2012.

NEW! ISMRM Meetings App

Be the sole sponsor or a daily sponsor of the ISMRM meetings application for all hand held devices such as iPhones, Blackberrys and Androids. Have your ad pop up each time someone pulls up our app! Daily messaging with direct links to your booth or website. The possibilities are endless.

Refreshment Concessions

Meeting attendees consistently report their preference for easy access to coffee, tea and soda at our events. Sponsor as many refreshment breaks as you desire and place your company's brand on signage, cups, napkins, etc., in front of an appreciative audience.

NEW! Email Stations

Email stations are now open as a sponsorable item. System screens at each station will display a particular message of your choice daily for our attendees to view.

NEW! Product Display Bar

This is a new sponsorship which will be located on our exhibition floor in the ISMRM Resource Centre. A new Product Bar will display your medical or technical device, brochures, etc. This sponsorship is replacing the convention bag insert. Limited spaces will be available.

Educational Courses

Sponsor a course of your special interest and position your company's name in three highly viewed places: our Program-at-a-Glance (distributed to all attendees); on signage outside the session room door (viewed by heavy convention traffic), and on our website program.

Your Idea Here!

Let us know your great ideas for maximizing your exposure at the meeting through sponsorship. We welcome all suggestions and opportunities.

ISMRM Attendee Notebook

This comprehensive meeting planner is an attendee favorite in planning day-today meeting activities. As the exclusive supporter, you will receive maximum visibility with your target audience. It will hold the following information: Program-at-a-Glance, Event Information, Exhibitor List, Exhibit Hall Floor Plan, 12-month Calendar, Expense Report, Customized Planning Pages, Note Pages, Local Restaurants, Entertainment, Attractions, Currency Conversions Chart, etc. First come, first served!

T-Shirts

T-shirts are reported to be one of the most popular promotional items at ISMRM meetings. T-shirts can be distributed in the highly trafficked registration area. You may give away an existing company T-shirt, or incorporate the ISMRM meeting logo into your new design.

Meeting Home Page

The ISMRM web site is a highly trafficked website. In addition, 82% of our attendees register for the Annual Meeting online, as well as submit abstracts to the meeting electronically. Take advantage of the heavy MR community traffic by sponsoring our Annual Meeting home page (<http://www.ismrm.org/12>). You can feature your company's logo as well as a link to your home page.

Pens

We hand out over 6,000 pens to our attendees every year. Sponsor this popular item and see your company's name in the hands and pockets of all our attendees!

NEW! Proceedings & Educational Syllabus USB

Every attendee will receive one of these USB's with the proceedings and educational syllabus to take back to their offices and labs. Sponsorship of the USB will insure your company's logo prominently displayed on the USB artwork. First come, first served!

Program-at-a-Glance Booklets

Our pocket-sized program is designed to fit into our badge holders. It is a handy reference for attendees seeking meeting information at-a-glance. Your company's logo, and even a small ad, can be featured in this well-used publication.

Speaker Ready Room

Be seen in this highly trafficked area where industry leaders upload their presentations and visit many times throughout the week. With over 1200 speakers, this is certainly great coverage!

Banners in Approved Locations

Reinforce your company's brand in front of thousands of potential customers with your banner positioned in a strategic location at the convention center. Specifications will be provided upon request.

If you are interested in taking advantage of one of the above offers or have your own ideas that you would like to discuss, please contact:

Roberta A. Kravitz, ISMRM Executive Director
Email: roberta@ismrm.org

Sandra Daudlin, ISMRM Director of Meetings
Email : sandra@ismrm.org

Phone: +1 (510) 841-1899, Fax: +1 (510) 841-2340



Melbourne
A U S T R A L I A

2012 Exhibitor

Company Profile for Guide to the Exhibition

DEADLINE: 13 February 2012
Required for all exhibitors

Instructions: Insert a 200-word company profile and contact information below and email a pdf, or send your profile and contact information as text via email to Melisa Martinez at melisa@ismrm.org. Please do not fax. This information will be printed in the ISMRM 20th Annual Meeting & Exhibition publication of the Guide to Exhibition to all attendees. ISMRM reserves the right to make editorial changes based on space availability. Please contact Melisa if you wish to use your 2010 company profile.

Company Name: _____

Address: _____

City _____ State _____ Country _____ Postal Code _____

Telephone: _____ Fax: _____

Toll Free: _____ E-mail: _____

Company Web Site: _____

Company Profile:

Exhibitor's signature: _____ Date: _____



III Ancillary Meetings

Ancillary Meetings & Exhibitor Functions
Exhibitor Function Space Request



Melbourne
AUSTRALIA

2012 Exhibitor

Ancillary Meetings & Exhibitor Functions

DEADLINE: 17 February 2012

Exhibitors are **required** to inform the ISMRM of all functions they are planning regardless of location or arrangements. Failure to do so will cause the forfeit of priority points. Advance notice is necessary for the ISMRM to place exhibitor meetings and functions in blocked hotels. There is no meeting space available at the Melbourne Convention Exhibition Centre for exhibitor meetings and functions that are not included in the official program.

- Requests for meetings and social functions **must** be made through the ISMRM office in order to avoid conflicts with the ISMRM official program.

MEETING POLICY: Ancillary meetings and exhibitor functions involving meeting attendees may only take place outside of the official Society meeting program.
ISMRM official program hours:

Saturday, 5 May	08:00 hrs. - 17:00
Sunday, 6 May	08:00 hrs. - 19:15
Monday - Thursday, 7 – 10 May	08:00 hrs. - 18:00
Friday, 11 May	08:00 hrs. - 12:30

There will be an opening reception in the Exhibit Hall on the evening of Sunday, 6 May from 17:45 - 19:15 hours and a closing reception the evening of Thursday, 10 May. Exhibitors are strongly discouraged from holding events during these evenings as all delegates will be invited to these functions.

SPECIAL REQUESTS: Should you wish to ask for special consideration to host your meeting during the official ISMRM program, please submit your request in writing explaining who will be the attendees of your meeting. All special requests will be reviewed by the Program Committee Chairman. Requests for meeting space must be made through Sandra Daudlin, Director of Meetings.

DEADLINE: All requests for meeting space must be made in writing or submitted on the following form by 17 February 2012. **Requests will be processed and confirmed on a first-come, first-served basis.**

Questions? Please contact: Sandra Daudlin, Director of Meetings, Email: sandra@ismrm.org
Phone: +1 (510) 841-1899, Fax: +1 (510) 841-2340



elbourne
A U S T R A L I A

2012 Exhibitor

Exhibitor Function Space Request

DEADLINE: 17 February 2012
Complete one form per function

Meeting Title and/or Function Name: _____

Date of Function: _____

Starting Time: _____ am/pm Ending Time: _____ am/pm

Expected Attendance: _____ Coordinator/Organization: _____

Billing Address: _____

City	State	Country	Postal Code
------	-------	---------	-------------

Telephone: _____ Fax: _____

TYPE OF FUNCTION:

Meeting Meal Reception Other (Describe): _____

SPECIAL EQUIPMENT REQUIRED:

LCD Projector AV technician
 Overhead Projector Easel
 Screen Lectern
 Flip Chart Microphone
 Other (Describe): _____

ROOM SET UP:

Head Table (# of chairs required: _____)
 Theater Conference Style
 Classroom U-Shaped
 Hollow Square Banquet Rounds

HOTEL PREFERENCE (if any): _____

PLEASE NOTE: *After hotel assignment has been made by the ISMRM, you will be provided with your hotel contact with whom you may work logistically on your event.*

Please fax, or mail complete form to:

Attention: Sandra Daudlin
Sandra@ismrm.org
 Meetings Department
 2030 Addison Street, Suite 700, Berkeley, CA 94704 USA
 Fax: +1 (510) 841-2340



IV Registration

- Exhibitor Registration Form
- Waived Scientific Meetings Vouchers
- Exhibitor Guest Vouchers



2012 Exhibitor

Exhibitor Registration Form (Page 1 of 2)

DEADLINE: 09 March 2012

Please complete both pages

PLEASE NOTE: All badges are only available for onsite pick up.

Name: _____

Company Name: _____

Address: _____

City _____ State/province _____ Country _____ Zip/Postal Code _____

Telephone: _____ Fax: _____

E-mail Address: _____

Company name EXACTLY as it should appear on badge:

ATTENDEE NAME COMPANY NAME COMPANY LOCATION

SAMPLE BADGE

Signature of Official Representative

Please fax or mail completed forms to:

Melisa Martinez, Meetings Department
International Society for Magnetic Resonance in Medicine
2030 Addison Street, Suite 700, Berkeley, CA 94704 USA
Phone: +1 (510) 841-1899 Fax: +1 (510) 841-2340

Email: Melisa@ismrm.org

- CONTINUED ON THE NEXT PAGE -



Melbourne
AUSTRALIA

2012 Exhibitor

Waived Scientific Meeting Vouchers

WHAT YOU WILL RECEIVE:

- Exhibiting companies will receive one (1) waived scientific meeting voucher for each 3 m x 3 m space rented. The vouchers will be available for pick up at the Exhibitor Registration Counter by the Official Company Representative for distribution to individuals of choice. These individuals may then redeem their voucher for a Scientific Meeting badge on site at the ISMRM Registration Counter. The purpose of the Scientific Vouchers is to allow individuals to attend sessions of the Scientific Meeting that are of interest.
- Scientific Meeting Vouchers may be picked up on May 4, 2012 after 14:00 by the exhibiting company representative.
- Once redeemed, the Scientific Meeting badge will allow access into the Scientific Sessions and Exhibit Hall during open hours.

HOW TO EXCHANGE THE VOUCHER FOR A NAME BADGE:

- Each waived Scientific Meeting voucher, along with an onsite registration form, may be exchanged for a name badge at the Onsite Registration counter in the ISMRM Registration area in the Melbourne Convention & Exhibition Centre **ONLY** by the person intending to use it. Identification is required for issuance of waived Scientific Meeting badges.
- **NOTE:** Once you have distributed your allotted vouchers to your company's employees, they will become the responsibility of the voucher holder. We will not be able to reprint any Scientific Meeting vouchers onsite. **Once badges are claimed at the Exhibitor Registration counter, no changes, substitutions, or reprints will be permitted.** The onsite Exhibitor Registration staff will maintain a record of the employees who redeem their vouchers for name badges.

BADGE HOLDERS:

- The badge holders for the Exhibitor Waived Scientific badge will be different from any other delegate badge, denoting attendance as exhibitor personnel. Booth personnel will be able to easily identify the type of delegate entering their booth.

If you have any questions, please contact Sandra Daudlin, ISMRM Director of Meetings, at Sandra@ismrm.org or Melisa Martinez, Meetings Coordinator at Melisa@ismrm.org

Phone: +1 (510) 841-1899

Fax: +1 (510) 841-2340



Melbourne
A U S T R A L I A

2012 Exhibitor

Exhibitor Guest Vouchers

DEADLINE: 9 MARCH 2012

Complimentary guest vouchers allow you to invite guests to visit your booth in the Technical Exhibition for one day at no charge. You are welcome to invite anyone who would not otherwise qualify for general registration.

Exhibitors may order one (1) voucher per day, per 9 square meters of rented space, with a maximum of five (5) per day.

ONSITE GUEST VOUCHER REDEMPTION

Guests must bring their voucher to the Exhibitor Registration window at the Melbourne Convention & Exhibition Centre on the day they wish to visit your exhibit. Identification is required to issue guest badges. Attendees asking to visit your booth for an appointment who do not have a guest voucher will be charged the one-day exhibit hall fee of US\$20.00.

TOTAL NUMBER OF VOUCHERS REQUESTED: _____

(1 per day, per 9 square meter of space with a maximum of 5 per day)

CONTACT INFORMATION:

Company: _____

Official Onsite Representative: _____

Telephone: _____ Cell Phone: _____

Please fax this form to +1 (510) 841-2340 no later than 9 March 2012.

If you have questions, please contact Sandra Daudlin, ISMRM Director of Meetings, at

Sandra@ismrm.org or Melisa Martinez, Meetings Coordinator Melisa@ismrm.org

Phone: +1 (510) 841-1899

Fax: +1 (510) 841-2340



V Harry the Hirer – Booth Services & Decoration

- General Information
- Terms & Conditions
- Schell Scheme Package
- Schell Scheme Sign Confirmation
- Furniture Order Form & Stand Layout
- Lighting & Power Order Form & Stand Layout
- Rigging Order Form
- Exhibitor Banner Information



On behalf of the ISMRM 2012 committee, we thank you for your valued support and participation. This is the core document, one of a number of files that make up the full set of Exhibitor/Sponsor Briefing Notes (EBN's) for ISMRM 2012. The EBN's are vital reading, providing you with important venue rules/regulations, official contractors and contact details, deadlines/action items, exhibitor-move in and move-out information and other related matters to guide your preparation and maximise your investment.

This core document is complemented by a number of related weblinks and attached documents, all of which are listed afoot this page. Please read the core document firstly and then refer to related links/attachments as applicable.

Table of Contents	
Related Documents listing – Essential Reading/also available on ISMRM 2012 website via: www.ismrm.org	Afoot this page
Summary of Deadlines	2
Contact Details	2
Venue Dimensions: Snapshot	3
Venue Manuals/Service Order Forms	3
Official Stand Builder/Rigging Contractor: Harry the Hirer	4
Official Freight Forwarding/Transport/Logistics: Mendelsohn Event Logistics	4 & 5
Deliveries to Venue	5 & 6
Exhibition Hours	7
Custom-Built Stand Design for (RAW space) Prior Venue Approval Process	7
Custom Crew MCEC Induction Process	7
Items Requiring Prior Venue and Committee Approval	8
Exhibition Booth Inclusions	9
Registration Inclusions, How to Register, Additional Registration Costs	10
Complimentary Trade (Visitor) Passes	10
OHS, Safety Vests, Children/Open Toed Shoes, Custom Built Stand Cleaning	11
MCEC Loading Dock, Normanby Road, South Wharf	12
Deliveries to the Venue/Own Courier: Friday 4 th May 2012 ONLY	12
Move-In and Move-Out Dates and Times,	13
Trolleys, Freight & Customs Duties/Vehicle & Courier Access/On-site	14
Testing and Tagging	15

Related Documents: Essential Reading/Available on ISMRM 2012 website as follows:

<http://www.ismrm.org>

- MCEC Operations Manual – **essential reading for those with custom builds/raw space stands**
- MCEC Exhibitor Services Kit:
 - Section 1 Overview and Service Information – **essential reading**
 - Section 2 Service Order Forms – **essential reading**
 Both also available via: www.mcec.com.au/plan-an-event/downloads/
- Mendelsohn Transport Request Forms & Information
- Custom Stand Design Form (which must accompany your custom build design for approval please)
- Exhibition Floor Plan (subject to minor change without notice)
- Exhibitor Freight Delivery Label
- Harry's Shell Scheme Package Form & Order Forms for Furniture, Signage, Power & Lighting, Rigging
 - NES AV Forms
 - IKON Stand Cleaning Form

Summary of Deadlines – All items can be completed now if ready / or at latest by due date

Item	To	Due Date
Custom build stand design plan: RAW space only 3mtr x 6mtr or Larger Only	patti.mcdowell@freemanco.com	2 nd March
Items requiring prior venue approval		
MCEC Venue Services/Orders – complete all orders, i.e. Internet and communications requirements etc	exservices@mcec.com.au	2 nd March
Mendelssohn: Air Freight -Transport/freight, deliveries, off-site storage & fork-lifting as required	dmekhuri@mend.com	Air Freight 10 th April
Mendelssohn: Shipping –Transport/freight, deliveries	dmekhuri@mend.com	Ocean Shipping 29 th February
Harry the Hirer – complete fascia/furniture orders	genevieve@harrythehirer.com.au	13 th April
NES AV Forms	hire@nes.com.au	1 st April
IKON –Exhibitor Stand Cleaning Request Form	jamie.mcguinness@ikonservices.com.au	13 th April
Exhibitor Freight to venue (Thursday 3 May 08:00 – 17:00)	Refer/use ONLY attached label	

Contact Details:

Meetings Co-ordinator

Name: Melisa Martinez
 Company: ISMRM
 Address: 2030 Addison St.,
 Ste 700 Berkley, CA 94704
 Tel: +1 510 841 1899
 Fax: +1 510 841 2340
 E-mail melisa@ismrm.org

Director of Meetings

Name: Sandra Daudlin, CMP
 Company: ISMRM
 Address: 2030 Addison St.,
 Ste 700 Berkley, CA 94704
 Tel: +1 510 841 1899
 Fax: +1 510 841 2340
 E-mail sandra@ismrm.org

Exhibition Contractor/Rigging Contractor

Harry the Hirer
 Contact: Genevieve Tate -Co-ordinator
 81-95 Burnley St
 Richmond VIC 3121
 Tel: 03 9429 6666
 Fax: 03 9427 1637
 Email: genevieve@harrythehirer.com.au
 Web: www.harrythehirer.com.au

Freight Forwarder

Mendelssohn Event Logistics
 Contact: Danny Mekhuri
 40 University Avenue, Suite 400
 Toronto, ON Canada
 Tel: +1 416 863 9339
 Ext 106
 Fax: +1 416 863 514
 Email: dmekhuri@mend.com

Venue Contact

Melbourne Convention and Exhibition Centre
 Exhibition Centre: Bays 11 -13
 Exhibitor Services
 PO Box 286
 WTC Post Office
 Melbourne VIC 8005
 Tel: +61 3 9235 8110
 Fax: +61 3 9235 8121
 Email: exservices@mcec.com.au

Cleaning Contact

IKON Services
 Contact: Jamie McGuinness
 PO Box 543
 North Melbourne VIC 3051
 Tel: +61 3 9326 8011
 Fax: +61 3 9326 8022
 Email: jamie.mcguinness@ikonservices.com.au

Audio Visual Contact

NES Electronic Hire
 Contact: David Silver
 41 Brady Street
 South Melbourne VIC 3205
 Tel: +61 3 9676 9322
 Fax: +61 3 9676 9366
 Email: hire@nes.com.au

Venue – Dimensions Snap Shot

Venue Exhibition Area – Bays 13 – 20

- Ceiling Height: 18m
- Clear Hanging Height: 11.5m
- Maximum Build Height for all custom builds/RAW space stands is 10m

The MCEC Loading Dock is accessible via Normanby Road, Southbank. Load time is limited to 30 minutes and this is strictly enforced by the parking inspectors. For example, if you arrive 10 minutes late, you will only have 20 minutes load time.

- Loading dock roller door: Clear door width access is 8m
- Loading dock roller door: Clear door height access is 7m
- **NB: Roller Doors 1&2 only are 7.4m in width access and 6.8m in height**

Floor load limits:

20 kPa or two tonnes per square metre; for all loads over this limit written approval must be requested

Written approval from the venue is required to bring in any heavy and or vibrating equipment that might cause damage to the floor or any part of the Centre.

MCEC Operations Manual/via MCEC weblink: www.mcec.com.au/plan-an-event/downloads/ Pages 10 – 15

Venue: Melbourne Convention and Exhibition Centre Manuals & Service Order Forms

MCEC Operations Manual – **essential reading for those with custom builds/raw space stands**

MCEC Exhibitor Services Kit: Section 1 Overview and Service Information – **essential reading**
Section 2 MCEC Service Order Forms – **essential reading**

To access both documents please visit this MCEC weblink: www.mcec.com.au/plan-an-event/downloads/

Please ensure you are fully conversant with all venue rules and regulations: this is your responsibility prior to entering the venue; ignorance may lead to disappointment, exclusion and/or unexpected costs.

MCEC Service Order Forms can be found in Section 2: pages 50 – 84 MCEC Exhibitor Services Kit

Section 2 Service Order Forms

2.1 Exhibitor Services Account Form	50
2.2 Communication Order Form	51
2.3 Communication Lines Floor Plan	59
2.6 Utility Services	64
2.7 Cappuccino/Espresso Machine with a Skilled Barista	65
2.8 Stand Catering Guidelines for Ordering	68
2.9 Stand Catering Menu Selection	71
2.10 Sorbet and Ice Cream Cart Package	77
2.11 Stand Catering Guidelines for Ordering Drinks	82
2.14 Food and Beverage Outlet Account Card Order Form	84

Official Stand Builder / Rigging Contractor: Harry The Hirer

Exhibition Contractor/Rigging Contractor

Harry the Hirer
Contact: Genevieve Tate – Account Co-ordinator
81-95 Burnley St
Richmond VIC 3121
Tel: 03 9429 6666
Fax: 03 9427 1637
Email: genevieve@harrythehirer.com.au

Prior to the exhibition:

Genevieve will be in touch with current catalogue and booking forms/information. To facilitate this, your contact details have been passed on to Harry's. Please feel comfortable to contact Genevieve for all your requirements; including rigging. Deadline for orders and final fascia confirmation is **Friday 13th of April 2012.**

To access all Harry the Hirer Order Forms for ISMRM please visit this HTH weblink:

<http://www.harrythehirer.com.au/images/ISMRM-2012.zip>

Official Freight Forwarding / Transport / Logistics: Mendelssohn Event Logistics

Mendelssohn Event Logistics (MEL) has been appointed the official freight forwarder/logistics provider for ISMRM 2012. MEL provides a complete service including monitoring of freight from your door step through to your exhibition booth making sure your goods are handled in a professional manner and all formalities/deadlines are met. If you are using MEL, your goods will automatically be delivered to your exhibition booth in readiness for the Exhibitor move-in.

MEL offers the following services:

- All local, interstate & international transport services including delivery onto each exhibitors stand
- Storage of early consignments, packing materials during the exhibition and storage after the exhibition
- For international exhibitors, a comprehensive international freight forwarding service tailored to each particular **exhibitor's requirements**, customs clearance, tariff classification & advice, duty & sales tax assessments and all relevant documentation
- Transport, craneage, forklift, portorage, clearance, delivery, off-site storage, positioning of goods at your stand all other onsite services

Prior to the Exhibition:

MEL will make contact to discuss and determine your individual freight and logistics requirements. To facilitate this, your contact details have been passed onto MEL. To initiate a quotation simply complete and return the Mendelssohn Event Logistics Transport Request Form, **deadline for Air-Freight is 10th April and Ocean Shipping is the 29th February 2012.**

For any queries please contact:

Mendelssohn Event Logistics
Contact: Danny Mekhuri
40 University Avenue, Suite 400
Toronto, ON Canada
Tel: +1 416 863 9339 Ext 106
Fax: +1 416 863 5149
Email: dmekhuri@mend.com

On Site Materials Handling:

MEL will be operating a forklift service during bump in and bump out to assist exhibitors requiring forklifts, pallet jacks and flatbed trolleys. The cost for fork lifting on-site is \$75 for the first 15 minutes and \$65 every subsequent 15 minutes or part thereof. This is payable by credit card or cash at the time of booking with MEL. Please see the MEL staff at the loading dock for assistance.

Off-Site Storage:

All exhibitors must organise off-site storage with their freight company for all packing crates and freight forwarding materials for the duration of the exhibition. All large crates/skids must be placed into off-site storage until the conclusion of the exhibition as there is no storage space at the venue. Exhibitors cannot leave large boxes and/or packing material anywhere in the halls during the show; please plan to have all your goods stored off-site. MEL can arrange off-site storage at a cost of \$50.70 cm3 or part thereof.

Deliveries to Venue

There are three options to deliver your goods to the venue.

1. Official Freight Forwarding/Transport Services – Medelsohn Event Logistics (MEL)

This provides an all inclusive service comprising of delivery of your goods to your stand prior to move in, storage of your crates and boxes during the exhibition and collection/return of your crates/return freight at the end of the event. Using MEL provides you with a smooth move in/out process. Please contact Mel for a quotation for services required using the attached form: Mel Transport Request Form, or call directly.

2. Own Arrangements Courier – using your own courier

*This option is **ONLY** available from **Thursday 3rd - Saturday 6th May 08:00 – 17:00**
Sunday 7th May 08:00 – 14:00*

This option allows you to use your own courier, whereby you are responsible for organising all transport, handling and receiving arrangements for your display items for the move/in and out phases from door to door. Your company representative must be in attendance on site to take receipt of your goods and transfer/handle the goods from the loading dock to your stand.

Exhibitor goods can only be delivered to Melbourne Convention & Exhibition Centre Loading Dock on the days of the Exhibitor move in: Thursday 3rd May – Saturday 5th May from 08:00 – 1700 and Sunday 6th May 08:00 – 14:00 and an exhibitor company representative must be in attendance to take receipt of your goods.

Your courier (or your company representative signing for your goods) must deliver all goods directly to your stand, venue staff **do not** assist with transferring/handling items from the loading dock to your stand. MEL can assist here if required but costs will apply; contact MEL for a quotation if required.

NOTE: Deliveries made in the absence of an authorised exhibitor company representative will be turned away. Although there will be security on site, no responsibility can be taken for goods that are left on your stand unaccompanied. To ensure correct delivery to your stand, please use the attached MCEC Exhibitor Delivery Label on all boxes being delivered and be in attendance to receive and sign for your goods. MEL, MCEC, & HTH will not sign possession of goods from couriers on behalf of exhibitors or clients. To avoid issues with the delivery of your goods always ensure that a representative is on site to take possession of these goods. Goods must not be sent to the Loading Dock before the scheduled times for the move-in of your event. All goods must be collected by the end of the official move-out time.

3. Own Arrangements Personal Delivery – using your own private vehicle

*This option is **ONLY** available from **Thursday 3rd - Saturday 6th May 08:00 – 17:00**
Sunday 7th May 08:00 – 14:00*

This option allows you to use your own private vehicle, whereby you are personally responsible for organising all transport, handling and receiving arrangements for your display items for the move/in and out phases from door to door. Your company representative/driver/colleague must be in attendance on site to take receipt of your goods and transfer/handle the goods from the loading dock to your stand.

As there are no porters or trolleys available on site, we suggest you bring your own trolley and you must enter the exhibition via the Exhibition Centre Loading Dock.

Trolleys are not permitted at any time on the exhibition centre concourse.

NOTE: All vehicles entering the Melbourne Exhibition Centre Loading Dock will be issued a 30-minute unloading permit on arrival. Parking infringements will be issued by authorised officers of the City of Melbourne for those vehicles exceeding the 30 minute unloading rule.

Exhibition Hours

Thursday 3 rd May 2012	Freight Delivery	08:00 – 17:00
Friday 4 th May 2012	Exhibitor Move In	08:00 – 22:00
Saturday 5 th May 2012	Exhibitor Move In	08:00 – 22:00
Sunday 6 th May 2012	Exhibitor Move In	08:00 – 14:00
Sunday 6 th May 2012	Poster Board Set-up Access	07:00 – 16:00
Sunday 6 th May 2012	Welcome Reception in Exhibition Hall	17:45 – 19:00
Monday 7 th May 2012	Exhibition Open	10:00 – 17:00
Tuesday 8 th May 2012	Exhibition Open	10:00 – 17:00
Wednesday 9 th May 2012	Exhibition Open	10:00 – 17:00
Thursday 10 th May 2012	Exhibition Open	09:30 – 16:30
Thursday 10 th May 2012	Exhibitor Move-out	17:30 – 2200

Times are correct at the time of printing but may be subject to minor change – exhibitor access will be granted 30 minutes prior to the listed times on Monday, Tuesday, Wednesday and Thursday.

EXHIBITION SCHEDULE: DESIGNED FOR MAXIMUM LEAD GENERATION

Activity	Thurs. 3 May	Fri 4 May	Sat. 5 May	Sun 6 May	Mon. 7 May	Tues. 8 May	Wed. 9 May	Thurs. 10 May	Fri. 11 May
Freight-Move-in	08:00–17:00	x	x	x	x	x	x	x	x
Installation of Exhibits	x	08:00–22:00	08:00–22:00	07:00–14:00	x	x	x	x	x
All exhibits must be fully operational	x	x	x	14:00: If materials have arrived but installation of any exhibit has not started by 14:00 hours on Sunday 6 May, and no special arrangements have been made, the Executive Director of ISMRM may order the exhibit to be removed from the show floor and placed in storage and the exhibitor will be billed for all charges incurred. Any exhibit space not set up by 14:00 hours on Sunday 6 May, for which no special arrangements have been made, may be resold or reassigned by the ISMRM without obligation on the part of ISMRM for any refund whatsoever.					x
Exhibitor-Registration	x	14:00–20:00	06:30–18:00	07:30–18:00	06:30–18:30	06:30–18:00	06:30–18:00	06:30–18:00	x
Exhibition Days	x	x	x	17:45–19:15 Opening Reception	10:00–17:00	09:30–17:00	09:30–17:00	09:30–16:30	x
Poster Hours	x	x	x	Poster Installation 07:00–14:00	07:00–20:30	07:00–19:45	07:00–21:30	07:00–16:30	x
Move-Out/ Dismantle	x	x	x	Dismantle of an exhibit prior to 16:30 hours on 10 May 2012 is not permitted. Any company violating this regulation will forfeit priority points, which will affect floor space assignments for future meetings. All exhibitors will begin dismantle at 16:30, Thursday, 10 May. The exhibition hall must be empty by midnight.					x

NEW AND IMPORTANT SECURITY GUIDELINES

Due to overwhelming requests from our attendees to extend poster viewing hours, the ISMRM Board of Trustees has agreed it is in the best interest of our attendees to do so. Therefore, the exhibition floor will be open for longer hours in order to accommodate poster viewing. While exhibition hours will remain the same, this change simply indicates that when the Technical Exhibition closes at 17:00 daily, the exhibit hall will remain open for poster viewing. There will likely be thousands of people still roaming around viewing once you have left your booth for the day. Due to this change, it is recommended by the ISMRM for all exhibitors to consider purchasing additional security measures or securing booth valuables in a locked cupboard. While the ISMRM will provide perimeter security and walk-about security in the exhibition hall, we are not responsible for booth security. Please consider this point carefully and remember to order your own security or lockable cupboards to support valuables. Booth security forms and lockable furniture rentals will be available in our Exhibitor Service Kit which will go live online 21 January 2012 to all paid exhibitors.

Custom-Built Stand Plans Requiring Prior Venue Approval

If you have purchased RAW Space for a custom built stand, please email a fully-dimensioned design plan **by Friday 2nd March 2012 to patti.mcdowell@freemanco.com** will seek the required prior venue approval to build and will advise you by return.

Approval must be granted prior to your build crew gaining access to build. Please also note that access for building and dismantling any custom booths will be organised around the main Exhibition Contractor, who has priority.

Custom Crew Team MCEC Induction – required prior to entry to the venue

To gain entry to the Loading Dock to build, all contract crew staff must complete both the MCEC induction and the Brookfield Multiplex Induction.

Both can be completed on line at: [Downloads for Organisers | MCEC](#)

Items requiring prior approval include:

- all vehicles – trucks/cars etc
- all items greater than 2.4m in height, two-storey stands
- any raised or feature flooring on stands
- additional lighting, use of naked flames, LP Gas cylinders
- **any food and or beverage items for sampling; no matter how small, these need approval**
- all prize draws
- helium balloons
- machinery
- tobacco
- refrigerators
- livestock/animals
- harmful chemicals
- talent on the floor
- anything loud/harmful/intrusive to others and anything outside the dimensions of your allocated booth space
- **heavy/vibrating equipment/anything that emits smoke/fumes**
Written approval from the venue is required to bring in any heavy and or vibrating equipment which might cause damage to the floor or any part of the centre
- **any food items or beverage items for sampling – MCEC approval is required**
All food and beverage must be ordered directly from the venue using the applicable forms. No outside food and beverages can be brought into the venue; this is strictly forbidden

NB: If you are including any of these items in your display (or any other items you think may need approval) please forward the details to Patti McDowell via patti.mcdowell@freemanco.com

Please refer to Page 16, Section 1.4, of the MCEC Exhibitor Services Kit on the ISMRM 2012 website <http://www.isrm.org> for further details if required.

Exhibition Booth Inclusions

Design Your Own Stand

Raw Space for Custom Design: 3m x 3m

Standard Shell Package

Included in the cost of exhibiting is one full "walk in / walk out" exhibition stand which will contain the following:

Booth Size	3m wide by 3m deep with walls 2.4m in height – total area of each booth 9sqm
Walls	Octanorm 2.4mtr High, Alluminium Frame with 3mm White MDF infills
Carpet Tiles	Charcoal carpet tiles will be laid in the aisles only. Booth carpeting is not included and must be ordered on the Harry the Hirer Order Form refer page 5 of the brochure for rates
Fascia	Fascia panel 30cm deep finished in Octanorm Alluminium Frames
Lighting & Power	Lighting & Power not included, please refer to order forms for rates
Signs	One company name in computer cut vinyl standard style letters Maximum of 30 letters

Occupational Health and Safety

By entering the venue premises (MCEC) each exhibitor must, adopt and observe the contemporary occupational health and safety practices in place at the centre.

To review all MCEC OHS procedures which by entry to the venue implies agreement please review the following document; this is your responsibility prior to entry.

- MCEC Operations Manual – **essential reading see page 21**

Safety Vests

Due to increased awareness from WorkSafe Victoria, it is now mandatory for all Exhibitors to wear approved safety vests at all times during the bump-in/out and move-in/out periods as applicable. Harry the Hirer will be operating a service desk during the exhibition move-in and Safety vests can be provided for a \$15 security deposit on-site, which will be refunded on the return of the vest at the end of bump in.

Alternatively, you can pre-purchase your own vests for your staff so as to gain entry to the Exhibitor Move in and Move out.

The no vest, no entry policy will be strictly enforced.

Open Toed Shoes: not permitted / Children under 18: not permitted

People wearing open toed shoes, sandals or thongs and children under 18 are not permitted access to the exhibition halls during bump-in/out and move-in/out. Sorry no exceptions.

Cleaning of Custom Built Stands / Shell Scheme Upgrades

On-stand cleaning for custom built stands is a specialised service you may need to engage nightly, particularly if you are having a white feature flooring; this is expediently managed if you ensure your custom build company includes this service for you as part of your installation. Custom built stand cleaning is your responsibility.

If you are require additional overnight cleaning please contact **Jamie McGuinness at IKON** by e-mail on: Jamie.mcguinness@ikonservices.com.au for a quotation. Alternatively refer to the Cleaning Order within the manual.

MCEC Loading Dock

The MCEC Loading Dock is accessed via Normanby Road, South Wharf VIC 3006, Bays 13-20 are mid way and towards the southerly end of this diagram and are clearly marked on site.

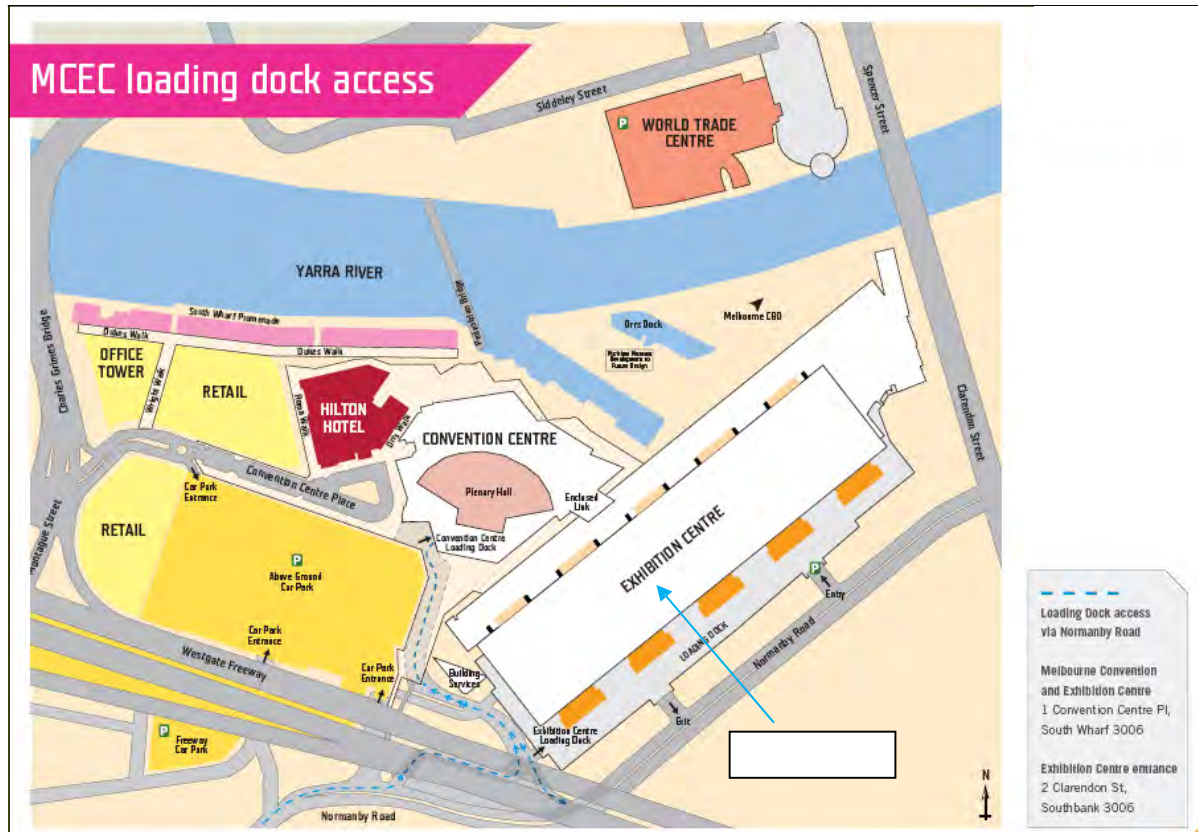

The Melbourne Convention & Exhibition Centre Loading Dock is a Self-Service Loading Dock.

No goods will be accepted on behalf of exhibitors by the Melbourne Convention & Exhibition Centre (MCEC), MEL or Freeman. Goods must not be sent to the Loading Dock before the scheduled times for the move-in of your event. All goods must be collected by the end of the official move-out time.

Freeman, the ISMRM Conference Committee, the Melbourne Convention and Exhibition Centre (MCEC), Harry the Hirer and their officers and employees, separately and collectively, will not take any responsibility for the safety or well-being of any goods, packages or material delivered to the site in the absence of the Exhibitor or his/her agent or contractor.

Deliveries to Venue by preferred courier or car: Saturday 5th- Sunday 6th May from 07:00 -14:00hrs ONLY

A company representative needs to be on site to receive any freight being delivered for you via private courier during the move in period; the MCEC staff cannot and will not accept any freight on your behalf.

Please use the attached MCEC ISMRM 2012 Exhibitor Freight Delivery label on all boxes being delivered.

Move-In Details

Move-In date: Friday 4th May 2012
Time: 08:00 – 22:00

Move-In date: Saturday 5th May 2012
Time: 08:00 – 22:00

Move-In date: Sunday 6th May 2012
Time: 07:00 – 14:00

✓ All booths must be completed by 1400

Move-Out Details

Move-Out date: Thursday 10th May 2012
Time: 16:30 – 21:00

- ✓ **Exhibitor move-out must be complete by 22:00**

IMPORTANT NOTES:

Please do not dismantle booth/s until the Exhibition area is clear of delegates.

A high-visibility safety vest must be worn by everyone involved in the move-in and move-out; no vest, no entry applies. Please pack vests for your staff; all staff on duty need to be vested prior to the commencement of the move-out, as the loading dock doors will only be opened for service once all staff involved are wearing safety vests and adequate closed footwear.

Courier companies should be instructed to pick up directly from your booth via:

MCEC Loading Dock: enter via Normanby Road, Southbank – please refer to map on Page 12
The packing up and removal of goods for return is solely the exhibitor's responsibility.

Please ensure the following items are packed in your on-site kit for the move-out:

1. Sufficient copies of the appropriate return address label
 2. Sufficient copies of your courier company's consignment notes, listing your company account number
 3. Knowledge of how to book a courier
 4. Packaging tape and scissors or a Stanley knife
- All goods must be removed from the venue at the conclusion of the Exhibition
 - Exhibitors must arrange for retrieval of their own empty cartons from storage at the conclusion of the event
 - Prior to leaving the site, staff must pack up all goods being collected by courier. All goods **must** have both a return address label and a completed courier consignment note attached, in readiness for the courier to collect directly from the booth

NOTE: Otherwise, goods will be deemed rubbish and disposed of promptly.

Items left with forwarding instructions, as detailed above, are to be collected by 22:00 on Thursday 10th May 2012; they cannot be left at the MCEC after this time. Alternately, if storage is required (after this time) so goods can be collected later, please make arrangements directly with your preferred supplier.

All goods remaining on the floor after 21:00 on Thursday 10th May will be returned automatically to Mendelssohn Event Logistics at your cost.

Trolleys

The MCEC does not supply any trolleys at all, so if you need a trolley, please bring your own.

Please note you may need to contact Mendelssohn Event Logistics if your need is greater than a small trolley.

Freight & Customs Duties

It is important that all Exhibitors have fully paid for all freight and customs. The ISMRM 2012 Conference Committee, the Melbourne Convention and Exhibition Centre (MCEC), Harry the Hirer and their officers and employees, separately and collectively, will not take any responsibility for items delayed at Australian Customs or for items that have not been paid for in full. Please note that GST will almost certainly have to be paid in full before goods are released from Customs.

Please contact Mendelssohn Event Logistics or your preferred courier for all national and international requirements.

Vehicle & Courier Access

All vehicle and courier access to the venue is via the Exhibition Loading Dock, entry via Normanby Street South Wharf.

Exhibition Storage On-Site

- Limited storage on-site is strictly for exhibitor replenishment of literature for on-stand distribution.
- All large crates/skids and packaging must be placed into off-site storage until the conclusion of the exhibition. This policy must be strictly adhered to, MEL can assist if required.

Security

24 hour security will be in place overall at ISMRM 2012; security guards will staff the exhibition entry points and the halls will be locked down nightly. If you require and wish to hire additional security for the items on your stand, please contact MCEC Exhibitors Services directly for a quotation.

Insurance & Public Liability

It is strongly advised that each Exhibitor seek to cover their equipment, exhibits and display materials with adequate insurance at the Exhibitor's own expense. It is the responsibility of all Exhibitors to ensure that they have adequate insurance.

Public Liability Insurance is mandatory whilst on site at the MCEC. Please ensure you locate and bring a copy of your Insurance Certificate of Currency to the venue – for which the venue has the right to ask for a copy at random should the need arise. \$20,000,000 in public liability is recommended.

Freeman, the ISMRM Conference Committee, the Melbourne Convention and Exhibition Centre (MCEC), Harry the Hirer and their officers and employees, separately and collectively, will not take any responsibility for any damage to or for the loss or destruction of an exhibit, from fire, theft or accidents or other causes, or injury to his/her person resulting from any cause, and all claims for any such loss, damage or injury are waived by the Exhibitor as per the signed terms and conditions upon application to exhibit and or sponsor.

Testing & Tagging – OZtag Testing & Tagging Onsite Sunday 6th May 2012 from 10:00 – 14:00hrs

Please note that all electrical leads (extension cords and or laptop leads) connected in any way to a power outlet need to be tested and tagged for use on site at the MCEC. It is best to have these items tested and tagged prior to bringing them on site.

It is a legal requirement in all temporary exhibition work sites within MCEC that all electrical equipment be tested and tagged. This applies to all contractors working on-site and exhibitors who bring in electrical leads and appliances of any sort for their stands during exhibitions. MCEC OHS Officer will make regular random checks on appliances and Exhibitors may be asked to show tags on demand.

Should you have the need to have any electrical gear tested and tagged, Oztag Testing and Tagging will be on - site from 10:00 – 14:00 on the Sunday 6th May. Tags cost \$16 each (CASH ONLY) and are valid for 12 months. Please note that testing and tagging is closely monitored at the MCEC, so if your equipment is not already tested and tagged use the services of Oztag during this window; once the technician leaves the building a \$250 call-out fee applies if you are asked to have items tagged.

1. Definitions

"Equipment" means the items hired out by the Owner to the Hirer. "Hirer" means any person who requests the Owner to hire Equipment to it, including its employees and agents. "Owner" means Harry the Hirer Pty Ltd., its employees and agents.

2. Terms of Payment

If required the Hirer will pay a deposit which will be forfeited if the Hirer breaches this agreement. Forfeiture will not affect any other rights of the Owner under this agreement. The Hirer agrees to pay the Owner's hire charge and any other charges, including charges for loss, damage and repairs or any tax, GST, duty, levy, or other expenses paid or payable by the Owner, at a time as specified by the Owner or, if not specified within seven days of the date of the relevant invoice. The Hirer agrees to pay any expenses incurred by the Owner as a result of breach by the Hirer of its obligations pursuant to this agreement (including legal costs on a solicitor-client basis).

3. Termination of Hire

The Owner may terminate the hire at any time. The Hirer shall have no claims for such termination. The Hirer may terminate the hire of the Equipment by:

- (a) returning the Equipment to the Owner during normal working hours; or
- (b) notify the Owner that the Equipment is ready for collection, provided that the Hirer keeps the Equipment safe until collection. Upon termination of hire, the Owner is entitled to take possession of the Equipment and for this purpose the Hirer irrevocably appoints the Owner as his agent and authorises the Owner to:
 - (a) enter upon any land or premises upon which the Equipment is situated or where the Owner has any reason to believe that the Equipment may be situated;
 - (b) remove the Equipment whether or not it is affixed to the land or premises, connected to property or equipment not owned by the Owner, in use by the Hirer or any other person or containing property not owned by the Owner. If the Equipment is not finally returned or ready for pick-up by the Owner at the expiration of the hire period the Hirer shall pay an additional charge of 100% the daily rate for every additional day or part thereof that the Equipment is retained by the Hirer unless otherwise specified.

4. The Hirer's Obligations

The Hirer will:

- (a) bear responsibility for the Equipment hired from the time of its delivery until collection by the Owner;
- (b) upon installation, delivery or collection of the Equipment immediately examine the Equipment to satisfy itself as to its condition and suitability and fitness for the purpose to which it requires the Equipment. In accepting the Equipment the Hirer acknowledges that it has duly examined the Equipment and has satisfied itself as required. The Hirer acknowledges that it has not in any way relied upon the skill or judgement of any representation made by or on behalf of the Owner in respect of the Equipment, its purpose or performance. Should the Hirer alter its installation or delivery requirements prior to, during, or after installation or delivery, the Hirer is liable for extra costs of the Owner's employees and cartage;
- (c) assume the risk of and indemnify and hold the Owner harmless from and against any and all property damage and personal injury resulting from:
 - (i) the use of the Equipment;
 - (ii) contact with underground cables, pipes, services or other obstructions;
 - (iii) all necessary surface repairs.
- (d) use the Equipment in a proper, safe and prudent manner and only for the purpose and capacity for which it was designed;
- (e) ensure all Equipment is returned or ready for collection by the Owner's driver, in a clean, dry and properly packed condition and if being collected, is readily accessible. The Hirer will pay for cleaning or drying and for any damage resulting from not properly drying, cleaning and/or packing the Equipment.

5. Property

The Hirer acknowledges that the Owner may inspect the Equipment at any time during the period of hire, whether notice of such inspection is given to the Hirer or not, and the Hirer shall provide all assistance and co-operation necessary to facilitate such inspection of the Equipment. The Hirer shall indemnify the Owner in relation to any action of trespass in the course of the Owner exercising its right to inspect the Equipment. The Hirer acknowledges his interest in the Equipment is as bailee of the Owner only.

6. Loss of or Damage to Equipment

If the Equipment is lost, breaks down or is damaged, the Hirer must immediately notify the Owner of the details. Notification shall not absolve the Hirer from its obligations under this agreement. In the event that the Equipment breaks down or becomes unsafe to use, the Hirer shall immediately stop using the Equipment and take all steps necessary to prevent the Equipment from sustaining any further damage.

The Hirer must also take all steps necessary to prevent injuries from occurring to any person or property as a result of the condition of the Equipment and not repair or attempt to repair the Equipment without the Owner's prior written consent. If the Equipment is lost or damaged and the loss of or damage to the Equipment is caused by the negligence of the Hirer or the breach of any term of this agreement by the Hirer, the Hirer shall be liable for the following;

- (a) any costs incurred by the Owner in repairing or replacing the Equipment;
- (b) hire charges for the Equipment until the Equipment is repaired or replaced;
- (c) any other costs whatsoever incurred by the Owner as a result of the damage to or loss of the Equipment.

7. Release and Indemnity

The Hirer hereby releases the Owner from, and agrees to indemnify the Owner in respect of any third party claims, action, suits, demands, costs and expenses for damage or injury to person or property arising directly or indirectly out of the hire or use of the Equipment by the Hirer or this agreement.

8. Damage Waiver

Damage Waiver is payable by the Hirer to cover the costs associated with the normal wear and tear to the Equipment. It does not apply to any other damage to Equipment including:

- (a) damage resulting from overloading, exceeding rated capacity, misuse, abuse or improper servicing of Equipment;
- (b) damage due to the mysterious disappearance of the Equipment;
- (c) damage caused by the use or operation of Equipment in contravention of any of the conditions of this Agreement;
- (d) damage to, or loss of, the Equipment from any unknown cause.

Insurance

The Hirer will maintain at its own expense all appropriate policies of insurance:

- (a) for theft and damage to the Equipment hired in an amount not less than the full replacement cost of the Equipment;
- (b) for liability, property and casualty insurance coverage in amounts necessary to fully protect the Owner and its Equipment against all claims, loss or damage whatever.

9. Force Majeure

If the Owner is unable at any time whether wholly or partly by reason of any cause beyond its control (including without limitation, acts of God, inclement weather, strikes, lockouts, fires, riots, civil commotion or unrest, interference by civil or military authorities or act of war) the Owner may give written notice to that effect to the Hirer, giving full particulars of such force majeure and the obligations of the Owner under these conditions shall, to the extent that they are affected by the force majeure, be suspended during the term of the force majeure. The Owner shall not be liable for any loss or damage suffered by the Hirer as a result of any delays caused by such force majeure events.

10. Miscellaneous

If this agreement or any part of it becomes void or unenforceable for any reason then that part will be severed from this agreement to the intent that all parts that do not become void or unenforceable will remain in full force and effect and be unaffected by any severance of other parts.

Failure by the Owner to insist upon strict performance of any terms contained herein, or to exercise in whole or in part any right that it may have under this agreement at law, shall not be deemed to be a waiver of any rights that the Owner may have and shall not be deemed a waiver of any subsequent breach of any term in this agreement.



Shell Scheme Package

Harry the Hirer has been appointed as the official stand contractor and supplier to the **ISMRM 2012 Conference and Exhibition**. The following information outlines the stand package inclusions for shell scheme exhibitors in inline booth spaces

If you wish to order online please visit our website at www.harrythehirer.com.au or if you require any assistance please do not hesitate to contact us directly:

Genevieve Tate - Coordinator

Phone: + 61 3 9429 6666

Email: genevieve@harrythehirer.com.au

Joel Cooper - Account Manager

Phone: +61 3 9429 6666

Email: joelc@harrythehirer.com.au

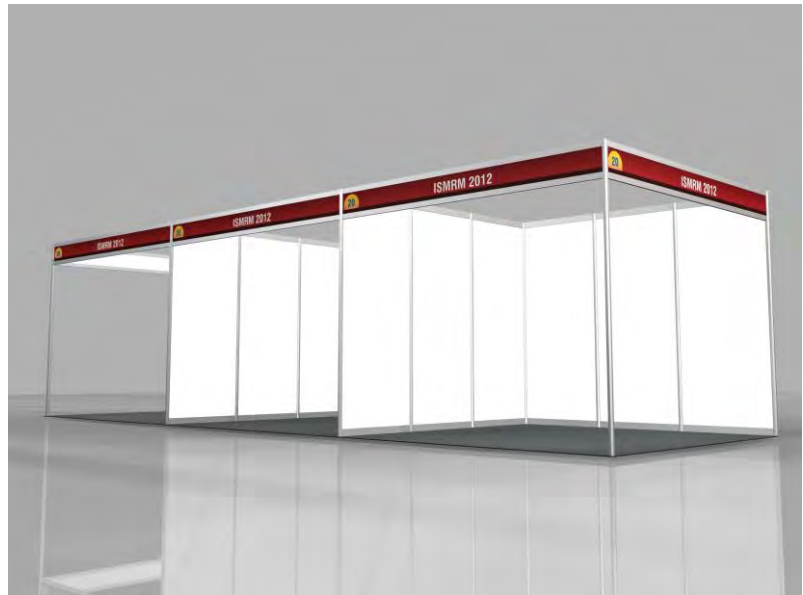

Carpet

Charcoal carpet tiles will be laid in the aisles only. Booth carpeting is not included and must be ordered on the Harry the Hirer Order Form refer page 5 of the brochure for rates



Charcoal

Walls

The shell scheme booths consist of White MDF Octanorm 2.4m high panels. The best method of affixing posters etc is to use velcro dots (male & female)

Furniture

Harry's has Australia's largest and most contemporary range of exhibition display equipment. Refer to our catalogue or visit our website to view the full range.

Fascia Sign

The fascia consists of a digitally printed panel insert 220mm high supported in an aluminium frame. The clear height under the fascia is 2100mm.

The company name will be printed in a white font that is 100mm high, with a maximum of 25 letters. One company sign will be provided per stand with corner stands to receive two.

Power & Lighting

Power & Lighting is not included as part of the standard package. We recommend that each 9mtr sqr stand have at least 2 x 70watt Enviro Lights and power if required.

Please refer to the Power & Lighting Order form for rates.

All order forms must be completed and returned to Harry's no later than Friday the 13th of April 2012.



81 – 95 Burnley Street
Richmond, Victoria 3121
Australia

www.harrythehirer.com.au

CLIENT DETAILS:

Exhibition / Conference: **ISMRM 2012**

Stand No:

Stand Dimensions:

Please sketch your desired layout of furniture and fittings

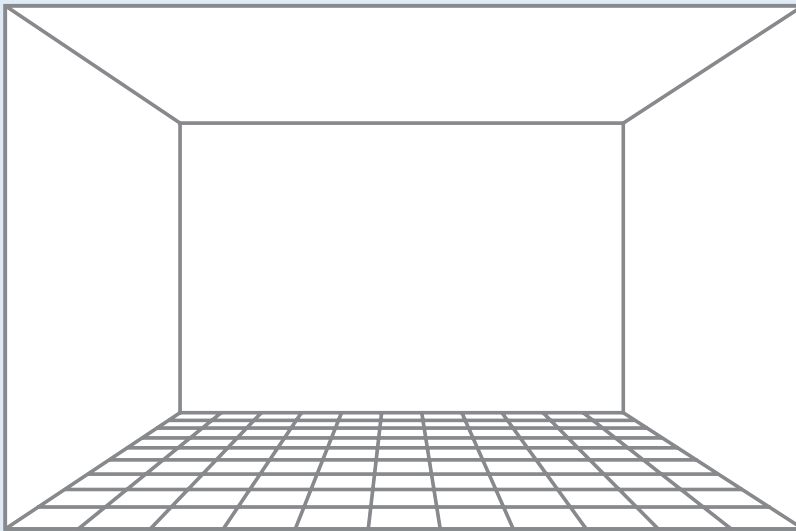

FRONT OF STAND

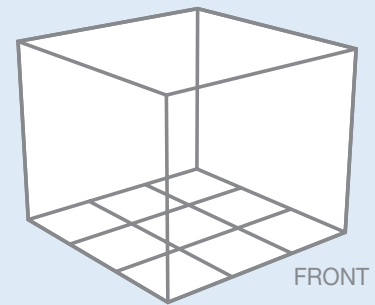

FRONT

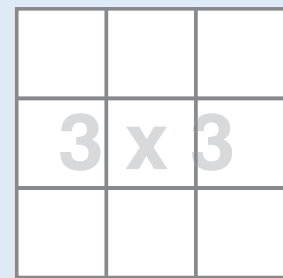

FRONT OF STAND

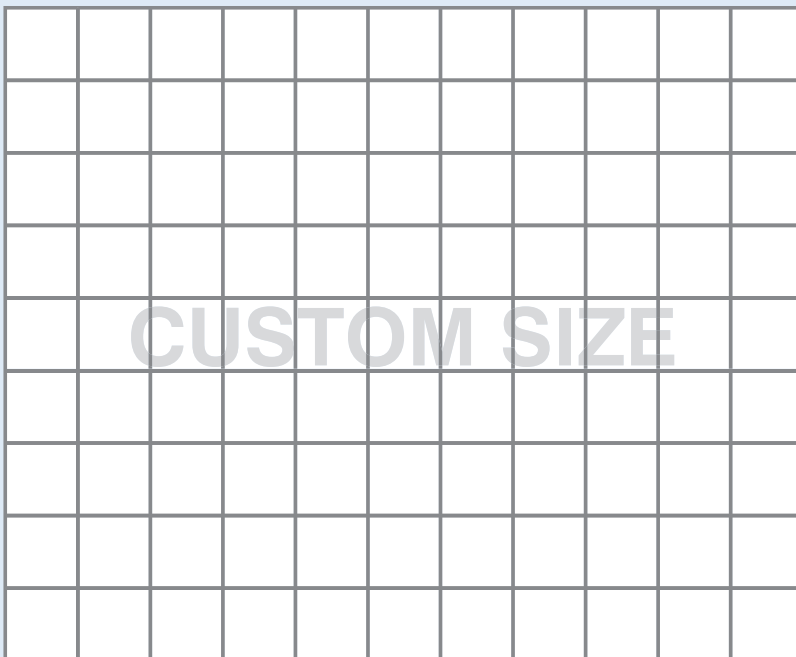

FRONT OF STAND

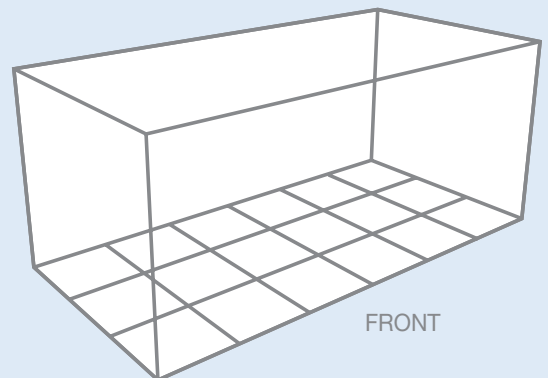

FRONT

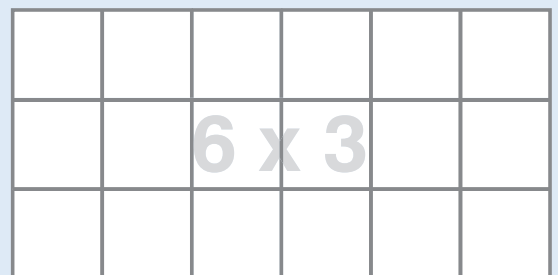

FRONT OF STAND

CONTACT DETAILS:		STAND DETAILS:	
Company Name:		Exhibition/Conference: ISMRM 2012	
Address:		Start Date: 06/05/12	Finish Date: 10/05/12
		Venue: MCEC	
State:	Postcode:	Stand No:	
Contact Name:		Stand Name:	
Telephone:	Facsimile:	Purchase Order No:	
Mobile:		Special Instructions:	
Email:	1111		

DO YOU REQUIRE EXTRA ELECTRICS FOR YOUR STAND? (PLEASE TICK)

YES (Please complete details below) NO (Please fax this confirmation)

ORDER INFORMATION: (Refer to the Exhibitions & Conferences catalogue)			
Description	Quantity	Rate (\$)(ex. GST)	Total (\$)(ex. GST)
POWER POINTS			
Single Power Point. Max 4amps/240vt/960wt		50.40	
Double Power Point. Max 10amps/240vt/2400wt		72.45	
Single Power Point. Max 15amps/240vt/3600wt		81.90	
Single Power Point. Max 20amps/240vt/4800wt		94.50	
3 PHASE POWER OUTLETS			
Three Phase Outlet - 415 Volt 5 Pin - 20Amp		199.50	
Three Phase Outlet - 415 Volt 5 Pin - 32Amp		278.25	
LIGHTING			
70wt Enviro Spot - Metal Halide - Fascia mount		45.15	
70wt Enviro Spot - Metal Halide - Arm mount		48.30	
120wt Spotlight on Track - Standard modular booth package light		45.15	
120wt Spotlight on Arm - General Floodlight for lighting products and posters		48.30	
300wt on Arm - Broad floodlight for lighting 3 metres of display wall		71.40	
500wt Floodlight - General floodlight for use on front fascia or high mounted on shell scheme wall		60.00	
1500wt Floodlight - Broad, General floodlight for use on 4.2m lighting pole or overhead rigging		78.00	
12v 50wt Light - For lighting products or posters		55.65	
12v 50wt Pencil Light		55.70	
150wt Metal Halide Floodlight		63.00	
400wt Metal Halide Floodlight		115.50	
575wt MSR Multipar		115.00	
1000wt Can Floodlights (min 2) - High powered floodlights, must be high mounted		73.50	
575wt Multipar Floodlight (Silver/Black)		70.00	
4.2m Lighting Pole on Base Plate (1m dia)		63.00	
Fluorescent Light 120cm - Coloured globes available		55.65	

EQUIPMENT TOTAL

add 7.5% of Equip.Total - Damage Waiver

add 32% of Equip.Total - Labor & Delivery

Total

add 10% GST

INVOICE Total (GST incl)

*Changes on-site to location of power & lights will incur a \$55 fee

*Late & on-site orders will incur a 20% surcharge

CONTACT DETAILS:	
Company Name:	
Address:	
State:	Postcode:
Contact Name:	
Telephone:	Facsimile:
Mobile:	
Email:	1111

STAND DETAILS:	
Exhibition/Conference: ISMRM 2012	
Start Date: 06/05/12	Finish Date: 10/05/12
Venue: MCEC	
Stand No:	
Stand Name:	
Purchase Order No:	
Special Instructions:	

TERMS & CONDITIONS:

- A connection fee applies to space-only stands and stands not ordered through Harry the Hirer.
- Power points will be located in a rear corner of the stand (unless otherwise specified on diagram below)
- Orders placed during move-in or on-site incur a 20% surcharge. Changes on-site to location of power/lighting will incur a \$55.00 charge.
- Goods will not be delivered until payment is received & cleared.
- All goods delivered and then cancelled will be charged at half rate plus cartage.
- * Late orders received less than seven days from exhibitor move-in will incur a 20% surcharge fee.

Harry the Hirer is not responsible for any goods left in or on our equipment after the exhibition closes.

Please indicate where you would like your electrics located (on diagrams below)

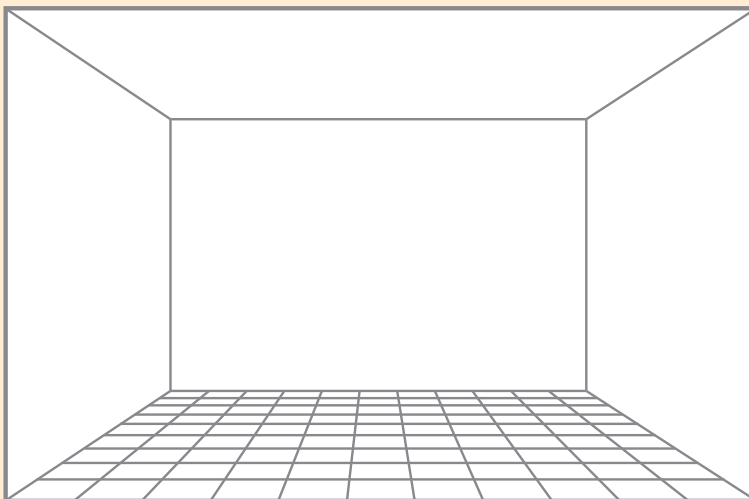

FRONT OF STAND

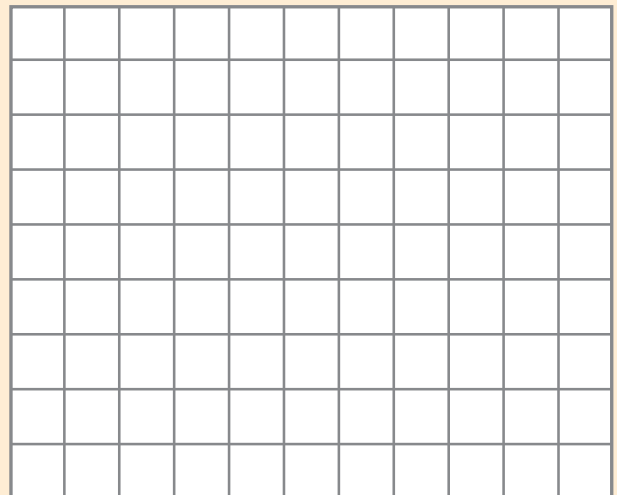

FRONT OF STAND

PAYMENT INFORMATION	
<input type="checkbox"/> Cash <input type="checkbox"/> Cheque <input type="checkbox"/> American Express <input type="checkbox"/> Diners Club <input type="checkbox"/> Visa <input type="checkbox"/> BankCard <input type="checkbox"/> MasterCard	
Account Name:	
Credit Card Number:	<input type="text"/> <input type="text"/> <input type="text"/> <input type="text"/> <input type="text"/> <input type="text"/> <input type="text"/> <input type="text"/> <input type="text"/> <input type="text"/> <input type="text"/> <input type="text"/>
Amex ID Number:	<input type="text"/> <input type="text"/> <input type="text"/> <input type="text"/> Card Expiry Date: <input type="text"/> <input type="text"/> / <input type="text"/> <input type="text"/>
Signature:	
(Order invalid unless signed by the hire/cardholder)	

FAX
+61 3 9427 1637



MAIL
Harry the Hirer
81-95 Burnley Street
Richmond, VIC
AUSTRALIA 3121



ONLINE
www.harrythehirer.com.au



CONTACT DETAILS:

Company Name:	
Address:	
State:	Postcode:
Contact Name:	
Telephone:	Facsimile:
Mobile:	
Email:	1111

STAND DETAILS:

Exhibition/Conference: ISMRM 2012	
Start Date: 06/05/12	Finish Date: 10/05/12
Venue: MCEC	
Stand No:	
Stand Name:	

Please illustrate in the diagram below the position of the banner & direction the signage is to face.

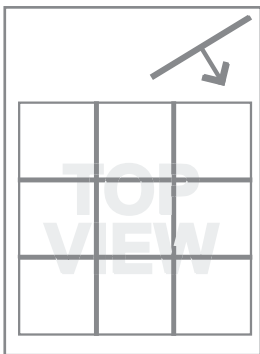

FRONT OF STAND

BANNER DIMENSIONS

Length:m
Width:m
Weight:.....kg

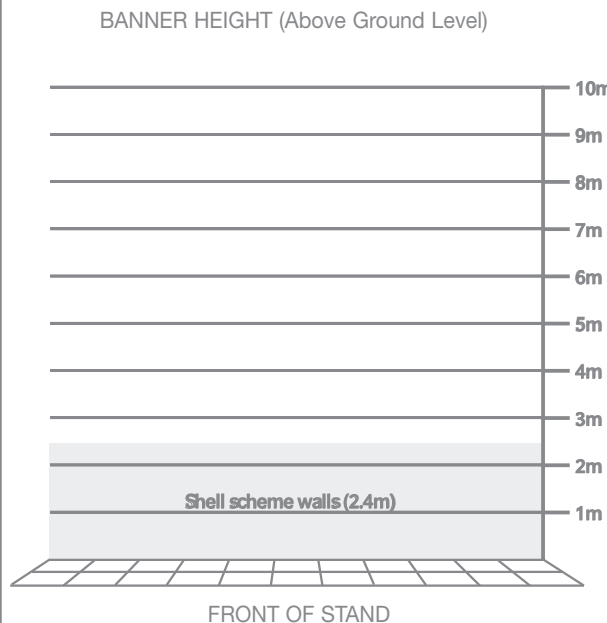

TICK BOX & COMPLETE FORM FOR A QUOTATION

Banner Suspension

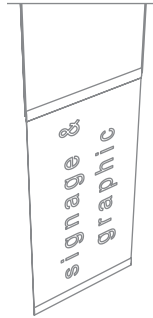

Truss & 1500wt QI Flood Lights or 400wt Metal Halide Flood Lights

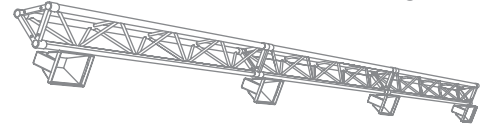

Truss & 1000wt Flood Lights

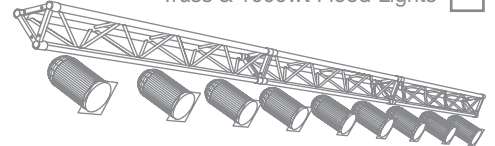

Banner, Truss & 300wt Arm Lights

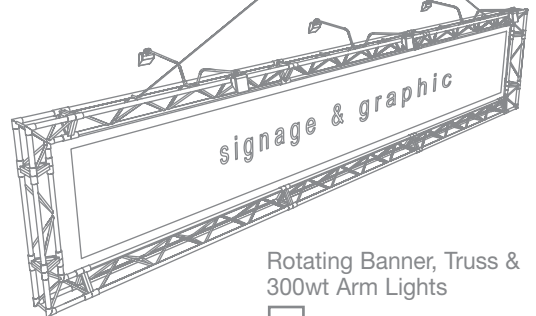
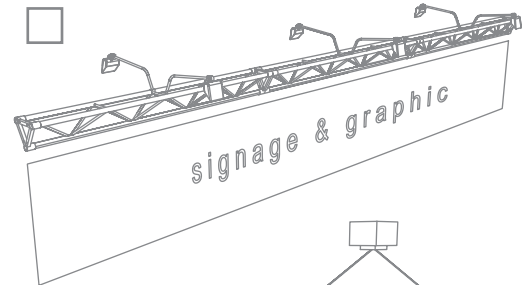

Rotating Banner, Truss & 300wt Arm Lights

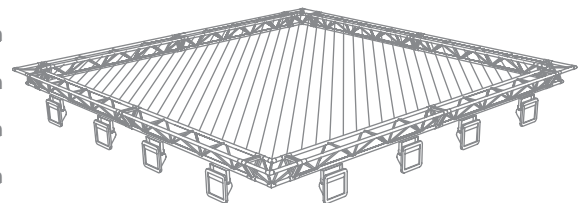

Truss & Fabric (wide range of colours available) 400wt Metal Halide Flood Lights

TERMS & CONDITIONS:

All banners must be delivered to Harry the Hirer no later than seven working days prior to installation. Please note any banner received after this date is subject to a 20% rigging surcharge. Harry the Hirer accepts no responsibility or cost incurred in the delivery & return of banners supplied. A charge of \$55.00 will apply to every banner that is supplied without suspension rods (if required). Please note all banners are required to have clearly marked exhibitor stand details & contact number. All banners are to be collected from site during move-out. Banners & Trussing final locations are subject to available suspension points at time of installation. Harry the Hirer will endeavour to collect any remaining banners from the site, but accepts no responsibility for the loss or damage of them from this time onwards.

CONTACT DETAILS:

Company Name:	
Address:	
State:	Postcode:
Contact Name:	
Telephone:	Facsimile:
Mobile:	
Email:	1111

STAND DETAILS:

Exhibition/Conference: ISMRM 2012	
Start Date: 06/05/12	Finish Date: 10/05/12
Venue: MCEC	
Stand No:	
Stand Name:	
Purchase Order No:	
Special Instructions:	

GENERAL BANNER INFORMATION:

Description of Text or Images on Banner	Colour	Width (m)	Height (m)	Rods/Frame Included	Qty
1.				<input type="checkbox"/> Yes <input type="checkbox"/> No	
2.				<input type="checkbox"/> Yes <input type="checkbox"/> No	
3.				<input type="checkbox"/> Yes <input type="checkbox"/> No	
4.				<input type="checkbox"/> Yes <input type="checkbox"/> No	
5.				<input type="checkbox"/> Yes <input type="checkbox"/> No	
6.				<input type="checkbox"/> Yes <input type="checkbox"/> No	

BANNER DELIVERY:

Banner Delivery to: <input type="checkbox"/> HTH Melbourne <input type="checkbox"/> HTH Sydney <input type="checkbox"/> Venue	
Name of Freight Company Booked:	
Date of Delivery:	Booking/Consignment Number (if applicable):

BANNER COLLECTION:

Banner Collection from: <input type="checkbox"/> HTH Melbourne <input type="checkbox"/> HTH Sydney <input type="checkbox"/> Venue	
Name of Freight Company Booked:	
Time & Date of Collection:	Booking/Consignment Number (if applicable):
Has the freight company been confirmed: <input type="checkbox"/> Yes <input type="checkbox"/> No	

RIGGING TERMS & CONDITIONS:

All banners must be delivered to Harry the Hirer no later than seven working days prior to installation. Please note any banner received after this date is subject to a 20% rigging surcharge. Harry the Hirer accepts no responsibility or cost incurred in the delivery & return of banners supplied. A charge of \$55.00 will apply to every banner that is supplied without suspension rods (if required). Please note all banners are required to have clearly marked exhibitor stand details & contact number. All banners are to be collected from site during move-out. Banners & Trussing final locations are subject to available suspension points at time of installation. Harry the Hirer will endeavour to collect any remaining banners from the site, but accepts no responsibility for the loss or damage of them from this time onwards.



VI Mendelssohn Event Logistics

- Shipping Instructions & Information
- Customs & Transportation Services Order Form
- Shipment Order Form
- Fumigation Release Form
- Advance Warehouse Order Form

ISMRRM 20th Annual Meeting & Exhibition

MELBOURNE CONVENTION & EXHIBITION CENTRE

MAY 5-11, 2012

SHIPPING INSTRUCTIONS

Danny Mekhuri
Operations Manager
Mendelssohn Event Logistics
40 University Avenue, Suite 400
Toronto, ON
Canada

Tel: 1-416-863-9339 ext. 106

Fax: 1-416-863-5149

E-mail: dmekhuri@mend.com

INTRODUCTION

Dear Exhibitor,

Mendelssohn Event Logistics has been appointed the official Customs & Freight Forwarding Agent for the ISMRM 20th Annual Meeting & Exhibition in Melbourne, Australia. We would like to ensure that your materials arrive “on time” in the most cost efficient manner. We suggest that you read these instructions in conjunction with the exhibitor’s manual provided by the Show Organizer.



Our helpful instructions will assist you in preparing for the correct, and timely, dispatch of your exhibits to Australia for the ISMRM 20th Annual Meeting & Exhibition. We highly recommend that you use the services of Mendelssohn Event Logistics for a complete logistics package. Our complete package will move your exhibit(s) door-to-door, from your country to your exhibition booth.

PLEASE NOTE: Failure to comply with the deadlines, consignee, and document instructions, will cause unnecessary delays in customs clearance and may lead to additional charges. For this reason, if you will be using a freight forwarder, other than Mendelssohn Event Logistics, please be sure to pass these instructions on to them.

Australia has many import restrictions and import permit requirements, especially for exhibitions. Invoices must be faxed or e-mailed to us for approval PRIOR TO shipping.

Mendelssohn Event Logistics will not accept responsibility for late arrivals, or non-deliveries, to the venue if these guidelines and/or recommendations are not followed.

CONSIGNEE INSTRUCTIONS

	<p><u>Consignee:</u></p> <p>Mendelssohn Event Logistics c/o Agility Fairs & Events Pty Ltd 28 – 32 Sky Road Melbourne Airport, VIC, 3045 Australia</p> <p>Attn: Rachel Larsen Tel: +61 3 9330 3303</p> <p><u>Notify:</u></p> <p>Same as Consignee c/o Show Name c/o Exhibitor / Stand Number</p> <p><u>DESTINATION: MELBOURNE AIRPORT</u></p>
	<p><u>Consignee:</u></p> <p>Mendelssohn Event Logistics c/o Agility Fairs & Events Pty Ltd 28 – 32 Sky Road Melbourne Airport, VIC, 3045 Australia</p> <p>Attn: Rachel Larsen Tel: +61 3 9330 3303</p> <p><u>Notify:</u></p> <p>Same as Consignee c/o Show Name c/o Exhibitor / Stand Number</p> <p><u>DESTINATION: MELBOURNE PORT</u></p>

CUSTOMS FORMALITIES/EXAMINATION

There are three (3) means of importing goods into Australia. They are as follows:

- **ATA CARNET**

Entry for goods under ATA Carnet allows for free movement of the goods within Australia after the exhibition for a period of up to twelve (12) months or until the expiry of the Carnet whichever occurs first, after which the goods must be re-exported (Under Customs supervision).

- **TEMPORARY IMPORT BOND (TIB)**

Mendelssohn, along with our Australian agent, is able to arrange for temporary entry of your goods against our security bond (TIB). Goods under Temporary Import must be under Mendelssohn/Australian Agent Control until it has been exported out of Australia, or finalized as a permanent entry.

- **PERMANENT IMPORT**

This is for goods which enter Australia for consumption, give away items, or goods that will remain in Australia, where import duty and Goods & Services Tax (GST) will apply. Please contact a Mendelssohn representative for Duty & GST % rates.

Please note: Give away items / brochures and leaflets for exhibitions purposes aren't exempt from GST and Duty. GST and Duty is payable on all give away items.

QUARANTINE

Australia, being an island, has stringent quarantine regulations. Any goods manufactured from plant materials are subject to quarantine inspection on arrival in Australia. These regulations cover items such as basket ware, cane ware, bark, wooden and bamboo goods, and straw articles. If goods are not absolutely free of rodent or insect infestation, they may be fumigated or destroyed at the discretion of the Quarantine Control Office.

Please note: Wooden packing materials (i.e. crates, pallets, etc.) are also subject to inspection!

AQIS will not accept Methyl Bromide Treatments carried out at less than 10°C.

If you intend to send wooden products or use your own wooden crates, please ensure proper ISPM 15 marking, or provide us with fumigation certificates. The fumigation certificates must show container numbers and bill of lading numbers as a numerical link to your shipment, such as one of the following:

Exhibitors must state on the Commercial documents whether timber or wooden packaging has been used in the shipment.

The freight forwarder or Shipping Line should also indicate packaging on the Bill of Lading i.e.

“4 wooden pallets STC 34 cartons” or “4 plastics pallets STC 34 cartons”

This will assist to determine whether treatment of the packaging is required. In regards to the packaging of your goods, please ensure no straw or plant materials are used in the packing of goods. It is suggested that paper, polystyrene, or man-made fibers be used for this purpose.

A Mendelsohn representative is only a phone call away and will gladly guide you through this process.

RESTRICTED ITEMS

In addition FOOD ITEMS, VEHICLES / BOATS, MILITARY / DEFENCE EQUIPMENT, WEAPONS, and any items containing CFS GAS (Fridges, Air-conditioning etc.) are subject to import permits. It is mandatory to contact us prior to sending to ensure permits are applied for and that the documentation provided is acceptable to Australian authorities.

DOCUMENTATION

In order to assist you in the preparation of the documents, we have designed a sample Commercial Invoice and Packing List for your reference. Please view the Commercial Invoice, which is located in the forms section of this manual, at your leisure.

Explanatory notes on the completion of the Commercial Invoice and Packing List form are as follows:

- **All information entered in these forms must be in English**
- **Indicate separate FOB and CIF Values on commercial invoice**
- **A full description of the item must be given. Please do not just indicate the model name, or model number. Also, vague descriptions such as “Exhibit Materials” or “Display Goods” will not be accepted.**
- **Describe the item-such as “1:3 scale (cutaway) model”, or “souvenirs-lapel pins”, or “wooden display shelves – floor standing”, etc.**

For specific machinery / tools / special items please note we require the HS no. / Code for classification.

Important

Please note Australian Customs Assesses Import duty and tax rates for every individual item, including give away items and brochures based on the CIF value.

This CIF Value is calculated as follows:

FOB Value + Insurance Value + Freight Value = CIF Value

Failure to indicate separate FOB and CIF Values will result in Australian Customs assessing the CIF value based on “average” freight and insurance amounts, or the freight amount shown on the AWB. This will result in higher Duty & GST amounts, or a higher temporary import bond fee.

This is an Australian Customs requirement and not within our control – therefore please clearly indicate separate FOB and CIF values on your commercial invoice.

- The following declaration must be indicated: “The invoiced goods are of ...(country)... origin and are intended for display purposes only at the exhibition site.”
- Exhibitors are to indicate the items that will be re-exported, as well as the items that will be disposed of, consumed, or given away at the end of the exhibition.
- Invoices must show the **full** description of goods, including unit prices, and totals.

Mendelsohn Representatives are available to walk you through these forms. Just give Danny a call at 416-863-9339 ext. 106, or send him an e-mail at dmekhuri@mend.com .

Additional Documentation:

Brochures and/or Illustrative Descriptive Material / website links:

- These should be supplied if you can't provide HS Codes. These documents will assist in the classification of exhibition goods for Customs purposes.

Fumigation Certificates:

- PLEASE NOTE the fumigation certificate is only accepted by Quarantine authorities if it indicates a numerical link such as container number or BL number.



Packing List:

- Must be provided and indicate:
 - Package number (must match the case / markings previously mentioned)
 - Full description of contents
 - Gross weight / Net weight / Dimensions
- A copy should be firmly attached to the case beneath the case mark. Customs may examine the goods on importation, so it is essential that a detailed packing list is provided to avoid delays in clearance.

Additional Requirements:

- Although it is not essential, to facilitate customs clearance, giveaways, brochures, etc, should be invoiced, and packed separately, if possible.
- All Cargo sent by sea freight requires a packing declaration. This document is mandatory and cargo can't be customs / quarantine released without it. Please view the Packing Declaration which is located in the forms section of this manual at your leisure.

ARRIVAL DEADLINES

	<p><u>DOCUMENT SUBMISSION DEADLINE:</u></p> <p>Mendelssohn Event Logistics must receive all completed Customs & Shipping documents by April 10, 2012.</p> <p><u>CARGO ARRIVAL DEADLINE VIA AIRFREIGHT:</u></p> <p>Your cargo Freight needs to arrive at MELBOURNE Airport: 7 working days before goods are due to be delivered to your stand.</p> <p><u>DOCUMENT DEADLINE VIA AIRFREIGHT:</u></p> <p>5 days prior to the arrival of the flight. Please ensure you send us a full pre alert containing the following documents:</p> <ul style="list-style-type: none">• flight number, weights and dimensions• A copy of the commercial invoice/packing list• AWB Copy <p>Original documents need to be attached to the AWB. Please note these deadlines are subject to General Cargo – For restricted items, Dangerous Goods, and perishable food items you will need to contact our office for confirmation of arrival deadlines.</p>
	<p><u>DOCUMENT SUBMISSION DEADLINE:</u></p> <p>Mendelssohn Event Logistics must receive all completed Customs & Shipping documents by February 29, 2012.</p> <p><u>CARGO ARRIVAL DEADLINE VIA SEA FREIGHT:</u></p> <p>Your cargo Freight needs to arrive at MELBOURNE Port:</p> <p>FCL CARGO: 7 working days prior to requested delivery to your stand.</p> <p>LCL CARGO: 14 working days prior to requested delivery to your stand</p> <p><u>DOCUMENT DEADLINE VIA SEA FREIGHT:</u> 10 days prior to the arrival of the vessel into Melbourne Port Please ensure you send us a full pre alert containing the following documents:</p> <ul style="list-style-type: none">• One original of Bill of Lading (or copy of express -release sea waybill)• Combined invoice and packing list• Certificate of treatment/fumigation if applicable and Packing Declaration

LATE ARRIVAL CHARGES

Goods, which arrive after these deadlines, will incur a surcharge on our inbound handling charges.

Please liaise with us should you have difficulty meeting the above deadlines, so that we can make arrangements for your freight. We advise you to follow the above deadlines to ensure that your exhibition materials arrive in a timely manner to avoid penalties for late arrival, which may be levied due to the additional customs clearance formalities.

**Shipments arriving prior to the above mentioned deadlines are subject to storage charges.

GUIDELINES AND HANDLING TARIFFS
ADVANCED WAREHOUSE SERVICES

If you ship your goods using a courier service, please ensure you send us a pre alert prior to the arrival of the goods, and ensure that import duties and taxes are prepaid. Mendelsohn Event Logistics, and our Australian partners, cannot be held responsible for any duties and taxes that may be levied.

All small parcel express, or courier shipments, must be consigned to the following address:

Mendelsohn Event Logistics
c/o Agility Fairs & Events Pty Ltd
28-32 Sky Road
Melbourne Airport, VIC 3045
Australia
Attn: Rachel Larsen
Tel: + 61 3 9330 3303
C/- SHOW NAME & BOOTH STAND NO.

Shipments designated for this event must be labeled with the following information:

Exhibitor name:
Stand number:
C/- Exhibition Name / Date:
Hall & Stand No:
Package number 1 of ...

**If you intend to ship your goods directly to show site, deliveries will only be accepted on, or after May 4, 2012.

DEADLINES

Courier shipments must arrive in our depot 2 working days prior to the beginning of the exhibition.

HANDLING

Mendelsohn Event Logistics, and our Australian partners, will receive shipments that are freight prepaid only (to include any duty and tax for the account of shipper) and customs cleared/released. Please note that any shipment valued in excess of AUD 1,000.00 will be subject to a formal customs declaration. To ensure that your shipment is tracked, send a copy of your shipment waybill, or consignment note, prior to shipment arrival in Australia to:

E-mail: dmekhuri@mend.com.com
Tel : 1-416-863-9339 ext. 106 (Danny Mekhuri)
Fax: 1-416-863-5149 (Attention: Danny Mekhuri)

HANDLING CHARGES & PAYMENT

- Receipt of couriers shipments in our warehouse, staging, and subsequent delivery to exhibition stand on the last day of the official move in period

Up to 50 kg	\$270.00 USD Minimum Charge
Over 50 kg	\$270.00 USD + \$2.50 USD per kg

PAYMENT OF HANDLING CHARGE

Exhibitors who intend to use the advance warehouse, need to arrange payment prior to the shipment being delivered to your stand. Mendelsohn Event Logistics accepts payment via major credit cards such as American Express, MasterCard, and Visa.

OUTBOUND – MOVE OUT AFTER THE EXHIBITION

Mendelsohn Event Logistics is able to pick up from your stand, and store goods temporarily for courier pick up, or arrange for the return freight. Contact us for further information on costing, if this service is required.

ADDITIONAL INFORMATION

Courier and/or express parcel companies do not have the capacity to handle temporary import customs clearance. For exhibitors with high value items for display and being re-exported from Australia, please contact us for assistance.

INSURANCE COVERAGE

While all care is taken by Mendelssohn Event Logistics, and our Australian partners, in handling shipments, no liability is accepted for any internal or non-visible irregularities to the contents of your shipment. We strongly recommend that exhibitors insure their shipments for the conveyance from origin to stand, including the transit storage in our advance warehouse. All transactions are undertaken subject to our Standard Trading Conditions.

All exhibitors should arrange a comprehensive coverage for their goods which covers shipment to Australia, the period of display, and which allows either return to the country of origin, or an appropriate disposal period at the conclusion of the exhibition.

PACKING & LABELING

Please remember that your goods will be loaded & offloaded several times en-route to Australia.

We suggest that your goods are well packed, preferably in wooden cases, or on pallets.

To ensure your goods can be quickly located at site or during transit, please mark each case/carton as follows, on at least 2 sides:

<p>SHOW NAME: c/o Agility Fairs & Events Pty Ltd Name of Exhibitor: Stand number: Case number: e.g. 1 of 5 / 2 of 5 Gross weight / Net weight / Dimensions</p>
--

TERMS OF PAYMENT

- For exhibitors who are utilizing Mendelssohn Event Logistics services, payment information must be provided prior to shipping.
- For exhibitors who are utilizing the services of another freight forwarder, payment must be arranged, by credit card PRIOR TO DELIVER TO THE STAND. The following rates will apply:

Up to 50 kg \$270.00 USD Minimum Charge
Over 50 kg \$270.00 USD + \$2.50 USD per kg

Order Form

Customs and
Transportation Services

MENDELSSOHN
EVENT LOGISTICS

The original of this form must be completed to ensure Customs Clearance.
Please accept this as your authority for Customs Clearance and / or Transportation Services.

We wish to use Mendelsohn Event Logistics services for: (please check one)

- Customs Clearance and Transportation (Shipment Order Form Required) Customs Clearance Only Transportation Only (Shipment Order Form Required)

Section 1 Exhibitor and Shipment Information

Exhibitor / Company Name: ABC COMPANY

U.S. Tax # or U.S. IRS Identification: 12-3456789

Event Name: ISMRM

Facility Name: MELBOURNE CONV. CTR. Event Date/s: MAY 5-11, 2012 Booth #: 123

Shipment Date: FEB. 1, 2012 From (City, State): CHICAGO, IL Carrier Name: MENDELSSOHN

It Consists Of (# of Cartons, etc.): 1 40' CONTAINER Weight: 10,000 lbs kgs

Rep At The Event: JOE SMITH E-Mail: JSMITH@ABCCOMPANY.COM Cell Phone Number: 555-555-1234

Please do not ship via post or parcel courier we will not be responsible for timely delivery

Section 2 Return Shipment Consignment Information

Company Name: ABC COMPANY

Address: 123 ANY STREET

City: CHICAGO

Province / State: IL

Postal/Zip: 12345

Name: JOE SMITH

Tel: 555-555-2345

Fax: 555-555-3456

Ship Via:

Ocean Freight Service Air Freight Service

Section 3 Terms of Payment and Security Deposit (Must be completed)

Credit Card Information must be completed

Charge to: Visa MasterCard American Express

Cardholder Name: JOE SMITH

Title: SALES MANAGER

Card Account Number: 123456789

Expiry Date: 04/14

Cardholder's Signature:

Joe Smith

I hereby authorize the use of this credit card for payment of services relative to this order form.

Alternative methods of payment are bank wire transfer or pre-payment on credit card (Receipt 10 days prior to event).

**NOTE: A 2% administrative fee (minimum \$25.00) will be charged for all credit card declines.

Section 4 Invoicing/Statement Information

Company Name: ABC COMPANY

Address: 123 ANY STREET

City: CHICAGO

Province/State: IL

Postal/Zip: 12345

Name: JOE SMITH

Tel: 555-555-2345

Fax: 555-555-3456

This document was completed by (Please print full name): JOE SMITH

Title: SALES MANAGER

Date: JAN. 12, 2012

Order Form

Customs and
Transportation Services

MENDELSSOHN
EVENT LOGISTICS

The original of this form must be completed to ensure Customs Clearance.
Please accept this as your authority for Customs Clearance and / or Transportation Services.

We wish to use Mendelsohn Event Logistics services for: (please check one)

Customs Clearance and Transportation
(Shipment Order Form Required)

Customs Clearance Only

Transportation Only
(Shipment Order Form Required)

Section 1 Exhibitor and Shipment Information

Exhibitor / Company Name:

U.S. Tax # or U.S. IRS Identification:

Event Name: 2012 ISMRM ANNUAL MEETING & EXHIBITION

Facility Name: MELBOURNE CONV. CTR.

Event Date/s: MAY 5-11, 2012

Booth #:

Shipment Date:

From (City, State):

Carrier Name:

It Consists Of (# of Cartons, etc.):

Weight: lbs kgs

Rep At The Event:

E-Mail:

Cell Phone Number:

Please do not ship via post or parcel courier – we will not be responsible for timely delivery

Section 2 Return Shipment Consignment Information

Company Name:

Address:

City:

Province / State:

Postal/Zip:

Name:

Tel:

Fax:

Ship Via:

Ocean Freight Service Air Freight Service

Section 3 Terms of Payment and Security Deposit (Must be completed)

Credit Card Information must be completed

Charge to:

Visa

MasterCard

American Express

Cardholder Name:

Title:

Card Account Number:

Expiry Date:

Cardholder's Signature: _____

I hereby authorize the use of this credit card for payment of services relative to this order form.

Alternative methods of payment are bank wire transfer or pre-payment on credit card (Receipt 10 days prior to event).

**NOTE: A 2% administrative fee (minimum \$25.00) will be charged for all credit card declines.

Section 4 Invoicing/Statement Information

Company Name:

Address:

City:

Province/State:

Postal/Zip:

Name:

Tel:

Fax:

This document was completed by (Please print full name):

Title:

Date:

Shipment Order Form

Customs and
Transportation Services
Tel: (416)863-9339
Toll Free: (800)665-4628
Fax: (416)863-5149

MENDELSSOHN
EVENT LOGISTICS

To obtain a quotation for Mendelssohn Event Logistics Transportation Services, please complete this form and fax to (416)863-5149.

Section 1 Pick-Up Information

Shipper: ABC COMPANY

Address: 123 ANY STREET

City: CHICAGO

State: IL

Zip: 12345

Contact: JOE SMITH

Tel: 555-555-2345

Fax: 555-555-3456

Hours of Operation: 9:00 AM - 5:00 PM

Section 2 Freight Information

COMMODITY: Exhibit Related Articles

Pick-Up Date: FEB. 1, 2012

To Arrive By: APR. 1, 2012

Mode of Transport: OCEAN FREIGHT

	Yes No		# of Pieces	Box/Crate/etc.	@ Dimensions Each:	Dimensions (inches)			@ Weight Each:	Per Piece
						Length	Width	Height		
Dock	<input checked="" type="checkbox"/>	<input type="checkbox"/>	5	CRATES	@ Dimensions Each:	40	40	48	@ Weight Each:	500 LBS
Liftgate Required	<input type="checkbox"/>	<input checked="" type="checkbox"/>	5	CASES	@ Dimensions Each:	20	24	32	@ Weight Each:	300 LBS
Hazardous Materials	<input type="checkbox"/>	<input checked="" type="checkbox"/>	10	BOXES	@ Dimensions Each:	30	24	24	@ Weight Each:	200 LBS
Insurance Required	<input checked="" type="checkbox"/>	<input type="checkbox"/>	1	PIECE	@ Dimensions Each:	50	72	50	@ Weight Each:	4000 LBS
Inside Pick-Up	<input type="checkbox"/>	<input checked="" type="checkbox"/>			@ Dimensions Each:				@ Weight Each:	
Inside Delivery	<input type="checkbox"/>	<input checked="" type="checkbox"/>			@ Dimensions Each:				@ Weight Each:	
Weekend Pick-Up	<input type="checkbox"/>	<input checked="" type="checkbox"/>			@ Dimensions Each:				@ Weight Each:	
Weekend Delivery	<input type="checkbox"/>	<input checked="" type="checkbox"/>			@ Dimensions Each:				@ Weight Each:	

Total Weight: 10000 LBS

Section 3 Event Information

Event Name: 2012 ISMRM ANNUAL MEETING & EXHIBITION

Event Location: MELBOURNE CONVENTION CENTRE

Consignee / Exhibitor Name: ABC COMPANY

Booth #: 123

Address: MENDELSSOHN EVENT LOGISTICS

C/O AGILITY FAIRS & EVENTS

28 - 32 SKY ROAD

TULLAMARINE, 3043 AUSTRALIA

- Upon receipt of this completed form, Mendelssohn Event Logistics will issue a quotation based on the information provided.
- In order to book your pick-up, the quotation must be signed and faxed back to (416)863-5149.
- All quotations provided by Mendelssohn Event Logistics are for Transportation ONLY and DO NOT include Customs Brokerage Charges.
- To receive a quotation for Customs Brokerage Charges and/or Cargo Insurance, a Commercial Invoice must be provided.
- If you are shipping hazardous materials, a Material Safety Data Sheet is required.
- Any additional requirements/special handling instructions should be documented on a separate sheet, and faxed in with this form.

Shipment Order Form

Customs and
Transportation Services
Tel: (416)863-9339
Toll Free: (800)665-4628
Fax: (416)863-5149



To obtain a quotation for Mendelssohn Event Logistics Transportation Services, please complete this form and fax to (416)863-5149.

Section 1 Pick-Up Information

Shipper: _____
 Address: _____
 City: _____ State: _____ Zip: _____
 Contact: _____ Tel: _____ Fax: _____
 Hours of Operation: _____

Section 2 Freight Information

COMMODITY: Exhibit Related Articles

Pick-Up Date: _____ To Arrive By: _____ Mode of Transport: _____

	Yes No		# of Pieces	Box/Crate/etc.	Dimensions (inches)			Per Piece
					Length	Width	Height	
Dock				@ Dimensions Each:			@ Weight Each:	
Liftgate Required				@ Dimensions Each:			@ Weight Each:	
Hazardous Materials				@ Dimensions Each:			@ Weight Each:	
Insurance Required				@ Dimensions Each:			@ Weight Each:	
Inside Pick-Up				@ Dimensions Each:			@ Weight Each:	
Inside Delivery				@ Dimensions Each:			@ Weight Each:	
Weekend Pick-Up				@ Dimensions Each:			@ Weight Each:	
Weekend Delivery				@ Dimensions Each:			@ Weight Each:	

Total Weight: _____

Section 3 Event Information

Event Name: 2012 ISMRM ANNUAL MEETING & EXHIBITION
 Event Location: MELBOURNE CONVENTION & EXHIBITION CENTRE
 Consignee / Exhibitor Name: _____ Booth #: _____
 Address: _____

- Upon receipt of this completed form, Mendelssohn Event Logistics will issue a quotation based on the information provided.
- In order to book your pick-up, the quotation must be signed and faxed back to (416)863-5149.
- All quotations provided by Mendelssohn Event Logistics are for Transportation ONLY and DO NOT include Customs Brokerage Charges.
- To receive a quotation for Customs Brokerage Charges and/or Cargo Insurance, a Commercial Invoice must be provided.
- If you are shipping hazardous materials, a Material Safety Data Sheet is required.
- Any additional requirements/special handling instructions should be documented on a separate sheet, and faxed in with this form.

COMMERCIAL INVOICE / PACKING LIST

Shipper Information	Consignee	Event
Company Name: ABC COMPANY Address: 123 ANY STREET Phone: 555-555-2345 E-mail: JSMITH@ABCCOMPANY.COM	Mendelsohn Event Logistics c/o Agility Fairs & Events - Melbourne 28-32 Sky Road Melbourne Airport, VIC 3045 Australia	ISMIRM 2012
Exhibition Information	Rachel Larsen 613 9330 9024	Hall / Stand Number
Representative at Exhibition: JOE SMITH Contact Number: 555-555-2345 Requested Delivery Date to Stand: MAY 3, 2012 Requested Delivery Time to Stand: NOON		123



Total no. of pieces	4 PIECES
Total weight in kgs	85 KG
Total cbm	0.368 CBM

Case / Box No	Dimensions in m's			Weight in KGS	HS Codes	Description of goods	Quantity	CIF value / AUD		Remarks *		
	Length	Width	Height					Unit value	Total value	A	B	C
1 OF 4	0.5	0.4	0.6	20 KG	4901.49	BROCHURES	40	\$0.60	\$ 24.00			X
2 OF 4	0.5	0.4	0.4	30 KG	6505.90	HATS	50	\$5.00	\$ 250.00			X
3 OF 4	1.5	0.5	0.2	20 KG	6307.90	BANNER	1	\$100.00	\$ 100.00	X		
4 OF 4	0.8	0.15	0.15	15 KG	4911.90	POSTERS	1	\$30.00	\$ 30.00	X		
Example												

* A = re-export after the event
 * B = to be disposed or consumed
 * C = given away/sold

FOB VALUE	\$	404.00
INSURANCE	\$	20.20
FREIGHT CHARGE	\$	337.50
TOTAL CIF VALUE	\$	781.70

The invoiced goods are of USA origin and intended for use at the event only.
 We certify that the information given above is true and correct, and that prices indicated represent the fair market value for the items described herein.

ABC COMPANY
 Company Name/Stamp

Name of Signatory in BLOCK LETTERS

JOE SMITH

Signature

Date

Company Letterhead

(MUST be issued by the packer or supplier of the goods and MUST include the company's name AND address)

FCL LCL PACKING DECLARATION

[Boxes to be marked in the appropriate place]

Vessel Name: _____ Voyage No.: _____
BOL No.: _____ Container No.: _____

PROHIBITED PACKAGING MATERIAL STATEMENT

(Prohibited packaging material such as straw, bamboo, peat, hay, chaff, used fruit & vegetable cartons)

Q1 Have prohibited packaging materials or bamboo products been used as packaging or dunnage in the consignment covered by this document?

A1 YES NO

TIMBER PACKAGING/DUNNAGE STATEMENT

(Timber packaging/dunnage includes: crates, cases, pallets, skids, and any other timber used as a shipping aid.)

Q2a Has timber packaging/dunnage been used in consignments covered by this document?

A2a YES NO

ISPM 15 STATEMENT

Q2b All timber packaging/dunnage used in the consignment has been treated and marked in compliance with ISPM15

A2b YES NO N/A

BARK STATEMENT

(Bark is the external natural layer covering trees and branches. This statement is only required if timber/packaging dunnage is declared using the timber or ISPM 15 statements. A bark statement is required for all timber packaging/dunnage including ISPM 15 compliant packaging/dunnage.)

Q3 Is all timber packaging/dunnage used in this consignment free from bark?

A3 YES NO N/A

CONTAINER CLEANLINESS STATEMENT (for FCL/X consignments only - statement to be removed from document when not relevant)

The container(s) covered by this document has/have been cleaned and is/are free from material of animal and/or plant origin and soil.

Signed: _____ Printed name: _____
(Company Representative)

Date of issue: _____
(DD/MM/YYYY)

FUMIGATION RELEASE FORM

_____ gives permission to Mendelssohn Event Logistics to fumigate all of our cargo for the ISMRM Trade Show once it lands in Melbourne, if deemed necessary.

_____ agrees to pay any of the fumigation costs in Melbourne, if deemed necessary.

Signing Officer Name – Please Print

Signing Officer Signature

Company Name – Please Print

Mendelssohn Event Logistics, Division of ICECORP Logistics Inc.

TORONTO, Head Office 40 University Avenue, Suite 400, Toronto, ON M5J 1T1 T: 416.863.9339	MTCC, South Building 222 Bremner Blvd., Room 825B Toronto, ON M5V 3L9 T: 416.585.8227	MONTREAL 276 Rue St. Jacques, Suite 818, Montreal, QC H2Y 2G4 T: 514.987.2700	CALGARY 2116 - 27 TH Ave., N.E., Suite 248 Calgary, AB T2E 7A6 T: 403.291.1694	VANCOUVER 1111 West Hastings St. Suite 901, Vancouver, BC V6E 2J3 T: 604.687.5535
--	--	--	--	--

All exhibitors intending to ship to the advance warehouse must complete this form.

Event Name: 2012 ISMRM ANNUAL MEETING & EXHIBITION

Facility Name: MELBOURNE CONV. CTR. Booth #:

Exhibitor:

Shipper:

Address:

Province/State: Postal/Zip Code:

Contact: Tel:

Fax:

Shipped via (Carrier Name):

Arrival Date: Delivery Date:

# of Pieces	Box/Crate etc.	Dimensions	Per Piece
		@ Dimensions Each:	@ Weight Each:
		@ Dimensions Each:	@ Weight Each:
		@ Dimensions Each:	@ Weight Each:
		@ Dimensions Each:	@ Weight Each:
		@ Dimensions Each:	@ Weight Each:
		@ Dimensions Each:	@ Weight Each:
		@ Dimensions Each:	@ Weight Each:
		@ Dimensions Each:	@ Weight Each:
		@ Dimensions Each:	@ Weight Each:

Total # of Pieces: Total Weight:

Credit card information must be complete.

Charge to: Visa MasterCard American Express

Cardholder Name: Title:

Card Account Number: Expiry Date:

Cardholder's Signature:

I hereby authorize the use of this card for payment of services relative to this order form.



VII Ancillary Services

- Audio Visual – NES Electronic Hire
- Janitorial / Stand Cleaning – IKON Services
- Melbourne Convention & Exhibition Center
 - Contents
 - Service Information
 - Service Order Forms



Melbourne
AUSTRALIA

ISMRM 20th Annual Meeting & Exhibition
SMRT 21st Annual Meeting
5 - 11 May 2012
Melbourne Convention & Exhibition Centre
1 Convention Centre Pl, South Wharf
Melbourne, Australia

Early Order Discount Deadline April 01, 2012

Company Information

Company Name: _____
Company Address : _____
City: _____ State: _____
Country: _____ Zip/Postal Code: _____
Ordered By: _____ Email: _____
Phone Number: _____ Fax Number: _____

Show Information

On Site Contact Name: _____ Cell / Mobile Number: _____
Booth Name : _____ Booth Number : _____
Requested Delivery Date: _____ Requested Delivery Time: _____

Payment Information

Credit Card Type: _____ Credit Card Number: _____ Expiry _____
Card Holder Name : _____
Card Holder Address: _____
Country: _____ Zip/Postal Code: _____
Card Holders
Signature: _____

By signing the above you are certifying the credit card information to be true and correct. You are authorizing the account to be charged for this advance order and any additional amounts incurred as a result of changes by on site representatives.

ALL PRICES ARE IN AUSTRALIAN DOLLARS. ALL CHARGES WILL BE IN AUSTRALIAN DOLLARS.

Orders may be emailed to hire@nes.com.au or faxed to +61 3 96769366

Additional equipment is available. Please call +61 3 9676 9322 for quote.

Equipment rental rates are show rates.

A representative must be in the booth to sign for equipment.

Cancellation of services must be received by discount deadline or cancellation minimums will apply.

Changes in delivery date or time on site may result in additional labor charges.

All equipment will be picked up by NES personnel upon completion of the event.



41 Brady Street, South Melbourne
 Victoria, Australia 3205
 ph: +61 3 9676 9322
 fax: +61 3 9676 9366



Booth Name _____
 Booth Number _____
 Date 5 - 11 May 2012

Flat Panel Monitors (Computer/Video)			
LCD / Plasma 16:9 Aspect Ratio	Qty	Standard Rate	Total
22" Flat Panel Monitor		\$ 270.00	\$ -
24" Flat Panel Monitor		\$ 330.00	\$ -
32" Flat Panel Monitor		\$ 450.00	\$ -
42" Flat Panel Monitor		\$ 750.00	\$ -
55" Flat Panel Monitor		\$ 1,185.00	\$ -
61" Flat Panel Monitor		\$ 2,250.00	\$ -

Touch Screen Monitors			
LCD 16:9 Aspect Ratio	Qty	Standard Rate	Total
46"		\$ 1,800.00	\$ -

LCD/Plasma ACCESSORIES			
Black Floor Stand		\$ 150.00	\$ -
Shelf for Floor Sand		\$ 75.00	\$ -
Wall Mount		\$ 75.00	\$ -

Specialty Display			
2X2 Seamless Plasma Wall (84")	Call Or Email	For Quote	
3X3 Seamless Plasma Wall (126")	Call Or Email	For Quote	
4X4 Seamless Plasma Wall (168")	Call Or Email	For Quote	
5x5 Seamless Plasma Wall (210")	Call Or Email	For Quote	

Playback			
DVD Player		\$ 120.00	\$ -
Blu-Ray Player		\$ 195.00	\$ -
Media Player		\$ 120.00	\$ -

Audio			
Speaker Systems (Powered)			
12" Speakers & Mixer (Pair with floor stands)		\$ 582.00	\$ -
Bose 101 & Mixer (Pair with floor stands)		\$ 315.00	\$ -
Bose 101 & Mixer (Pair with wall bracket)		\$ 315.00	\$ -

Microphones			
Requires Speaker System	Qty	Standard Rate	Total
Hand Held Wired		\$ 60.00	\$ -
Wireless Mic (Hand Held)		\$ 420.00	\$ -
Wireless Mic (Lapel)		\$ 420.00	\$ -

Computers			
Windows 7 Desktop (Includes LCD Monitor)			
Duo 2.33 - 2Gb RAM/160Gb HDD		\$ 148.00	\$ -
Quad 2.8 - 4Gb RAM/500Gb HDD		\$ 263.00	\$ -

Windows Notebook			
Duo 2.13 - 2Gb RAM/320Gb HDD		\$ 195.00	\$ -
Quad 1.6 - 4Gb RAM/500Gb HDD		\$ 295.00	\$ -

Printers			
Toner Charges Apply - Mono 7.7 cents per page, Colour 33 cents per page			
Mono Laser Printer (16 PPM)		\$ 125.00	\$ -
Mono Laser Printer (28 PPM)		\$ 163.00	\$ -
Colour Laser Printer (Duplex, 30 PPM)		\$ 355.00	\$ -
Laser MFC (Printer/Copier/Scanner/Fax)		\$ 240.00	\$ -

Accessories			
Remote Presenter		\$ 119.00	\$ -
Cordless Keyboard & Mouse Combo		\$ 119.00	\$ -

Totals			
Equipment Subtotal		\$	-
Add Service Charge 20% of equipment total(\$80 Minimum)		\$	80.00
Total		\$	80.00
20% Early Bird Discount if ordered & paid prior to 01-April-2012		\$	16.00
Grand Total		\$	64.00



EXHIBITOR STAND CLEANING REQUEST FORM

<u>SERVICES PROVIDED</u>	<u>INVESTMENT FEE</u> <small>(EXCL. GST)</small>
<ul style="list-style-type: none"> Remove hard rubbish, recyclables and litter. Wiping of table, chairs, benches, glass and other hard surfaces. Detailed vacuum of stand floor edging. Removal of non permanent scuff marks from hard floors. Mopping of all hard surfaces. 	<p>\$ 3.22 <i>Per square metre, Per service.</i></p>

<u>REQUEST DETAILS</u>	<u>INVESTMENT FEE</u> <small>(EXCL. GST)</small>		
<u>Event Details:</u>			
Exhibition/Conference:	<table style="width: 100%; border-collapse: collapse;"> <tr> <td style="width: 20%;">Total:</td> <td style="width: 10%;">\$</td> </tr> </table>	Total:	\$
Total:		\$	
Stand Name / Number:			
Stand size (sq mt):			
No. of services required:			
Dates of Services:			

<u>Contact Details:</u>	
Name:	
Position:	
Contact No.:	
Email:	

<u>Invoice To:</u>

TERMS:

- In the event that more hours are required to due to unforeseen circumstances and/or a greater than anticipated volume of cleaning, the Ikon representative will consult with the organiser to discuss the issues and get authorisation for any extra hours/costs required.
- The hours quoted are based on general light cleaning. Specialist cleaning includes, but is not limited to: steam cleaning, high level cleaning, pressure washing, paint removal, water damage all of which is charged separately at a rate of \$55.00 per hour.
- Payment 30 days from date of invoice.

Authorisation & Agreement to above Terms

Company:		Name:	
Purchase Order Number:		Signature:	
Date:			

EXHIBITOR SERVICES KIT

Melbourne Convention and Exhibition Centre

Melbourne Exhibition Centre

2 Clarendon Street, South Wharf 3006

Email: exservices@mcec.com.au

Melbourne Convention Centre

1 Convention Centre Place, South Wharf 3006

Email: exservices@mcec.com.au

Melbourne Convention and Exhibition Centre

GPO Box 777

Melbourne Victoria

Australia 3001

Telephone: (03) 9235 8000

Facsimile: (03) 9235 8001

Please note the above postal address is for MCEC internal items only. All event related items must be delivered by courier, or freight forwarder, to either the Melbourne Convention Centre or Melbourne Exhibition Centre Loading Dock.

CONTENTS

CONTENTS	2
0.1 OVERVIEW	3
0.2 EXHIBITOR EMERGENCY PLAN	4
0.3 PRIVACY.....	7
<u>SECTION 1 SERVICE INFORMATION</u>	
1.1 CAR PARKING RATES	9
1.2 MELBOURNE CONVENTION AND EXHIBITION CENTRE LOCATION MAP	12
1.3 DELIVERIES	13
1.4 EXHIBITS REQUIRING APPROVAL	16
1.5 FOOD AND BEVERAGE SAMPLING	22
1.6 EXHIBITION HALL DETAILS.....	44
1.7 RIGGING.....	45
1.8 UTILITY SERVICES	46
1.9 TRADE PROMOTION LOTTERY	48
<u>SECTION 2 SERVICE ORDER FORMS</u>	
2.1 EXHIBITOR SERVICES ACCOUNT FORM.....	50
2.2 COMMUNICATIONS ORDER FORM	51
2.3 COMMUNICATION LINE FLOOR PLAN.....	59
2.6 UTILITY SERVICES	64
2.7 CAPPUCCINO/ ESPRESSO MACHINE WITH A SKILLED BARISTA	65
2.8 STAND CATERING GUIDELINES FOR ORDERING	68
2.9 STAND CATERING MENU SELECTION.....	71
2.10 SORBET AND ICE CREAM CART PACKAGE	77
2.11 STAND CATERING GUIDELINES FOR ORDERING DRINKS.....	78
2.14 FOOD AND BEVERAGE OUTLET ACCOUNT CARD ORDER FORM.....	84



0.1 OVERVIEW

The Melbourne Convention and Exhibition Centre (MCEC) Exhibitor Services Kit is divided into two sections:

Section 1 - Explanatory notes on services provided.

Exhibitors should take the time to read this information as it will effect the way you operate within the Melbourne Convention and Exhibition Centre.

Section 2 – Service Order Forms

Pricing current at the time of producing this manual are provided, along with relevant order forms.

Operating procedures do vary between the Melbourne Exhibition Centre, and the Melbourne Convention Centre.

Please ensure you understand the procedures for the centre you will utilise.

Please note that all orders must be accompanied by the completed Exhibitor Services Account Form detailing your method of payment.

All prices quoted are inclusive of GST.

Payment is required prior to the provision of service and must be received one week prior to the commencement of the exhibition move-in.

Services cannot be provided without prior payment.

Completed order forms with payment should be returned to:

Melbourne Convention and Exhibition Centre
Exhibitor Services
GPO Box 777
Melbourne Victoria
Australia 3001
Tel: (03) 9235 8110
Fax: (03) 9235 8121
Email: exservices@mcec.com.au

Should you have any queries please don't hesitate to telephone the Exhibitor Services Department.

We look forward to welcoming you to the Melbourne Convention and Exhibition Centre.

0.2 EXHIBITOR EMERGENCY PLAN

This information is designed to assist you in running a smooth safe show by outlining some important safety aspects.

0.2.1 FIRE AWARENESS

It is illegal to do any of the following:

- Block or congest emergency exits. (These can be recognised by green and white exit signs over the doors).
- Block the access route to an emergency exit.
- Obscure or cover emergency exit signs.
- Store equipment or any other item in the fire stairs.
- Chock open fire or smoke doors or any doors leading to fire stairs

Please also see section 1.4 Stands Requiring Approval in this exhibitor manual.

MCEC MANAGEMENT WILL NOT CONDONE THESE PRACTICES AND ADHERENCE WILL BE STRICTLY ENFORCED.

0.2.2 EMERGENCY EVACUATION PROCEDURES

The MCEC has an Emergency Evacuation Plan to enable the successful evacuation of staff and visitors in the case of a fire or other emergency. All MCEC staff will assist in the evacuation of large numbers of people if the need arises.

Organisers are required to assign designated fire wardens to be present for the duration of the event. In addition it is important for all occupants of the MCEC to be aware of the Emergency Evacuation Plan:

The MCEC has two alarms, which can be heard throughout the building if a fire alarm is activated or there is a pending emergency.

The first alarm is the ALERT ALARM which is a BEEP-BEEP-BEEP sound (similar to a truck reversing). On hearing this alarm, all trained wardens will attend the Wardens Phones and await instruction from the Senior Warden.

ALL OTHER STAFF MEMBERS AND OCCUPANTS WILL CONTINUE ON WITH THEIR NORMAL DUTIES.

The second alarm is the EVACUATION ALARM which is a WHOOP-WHOOP-WHOOP sound (similar to an air raid siren). This is the signal for the wardens to evacuate the area via the fire stairs. LIFTS ARE NOT TO BE USED. You will then be guided to move quietly and calmly to the Assembly Areas.

0.2.3 EMERGENCY EVACUATION ASSEMBLY AREAS

Assembly areas for the MCEC are located at:

Area	Evacuation Assembly Point 1	Evacuation Assembly Point 2
Melbourne Exhibition Centre	Tea House Area	John Batman Park
Melbourne Convention Centre	Flinders Wharf Park (across the new Yarra River footbridge)	John Batman Park

Please take the time to familiarise yourself with emergency exits, fire fighting equipment and evacuation assembly points so that you can assist patrons of your show to safety if required.



0.2.4 EMERGENCY EXITS - IMPORTANT

Please take time to familiarise yourself with emergency exits.

0.2.5 CONTROLLING RISKS

Safety and security can only be achieved with the full cooperation of all staff and clients.

0.2.6 REPORTING INCIDENTS / NEAR MISSES

Report all incidents or near misses to the event organiser, event security or MCEC Security Control Room on ext 8333, or (03) 9235 8333. This allows for tracking and rectification of hazards and common problems.

0.2.7 SAFETY VESTS

Due to an increased awareness from WorkSafe Victoria it is now mandatory for all exhibitors during move – in and out periods to wear approved safety vests at all times.

Exhibitors and contractors will not be allowed entry to the exhibition floor unless safety vests are worn. Please contact your event organiser for further details.

0.3 PRIVACY

The Melbourne Convention and Exhibition Trust (MCET) respects your privacy and is committed to protecting the personal information you share with us in compliance with the Information Privacy Act 2000.

We will only collect this information when you place an order with Exhibitor Services at the Melbourne Convention and Exhibition Centre. Without this information we are restricted in our ability to service your requirements.

If you have any concerns and/or you wish to access your personal information please contact the Privacy Officer at privacy@mcec.com.au or (03) 9235 8000. A copy of the Privacy Policy can be obtained from the Privacy Officer or www.mcec.com.au

SECTION 1: SERVICE INFORMATION

Melbourne Convention and Exhibition Centre
GPO Box 777
Melbourne Victoria
Australia 3001
Telephone: (03) 9235 8000
Facsimile: (03) 9235 8001
Email: exservices@mcec.com.au



1.1 CAR PARKING RATES

1.1.1 MELBOURNE EXHIBITION CENTRE CAR PARK RATES

BASEMENT CAR PARK		
Entry and Exit via Normanby Road - 24 Hour Operation		
Day Rate: Monday to Friday (to 6:00pm)		
0 - 1 hour	\$8.00	Minimum
1 - 2 hours	\$16.00	
2 - 3 hours	\$24.00	
3 - 4 hours	\$32.00	
4+ hours	\$32.00	Maximum
Early Bird Rate: Monday to Friday (entry between 6:00am – 9:00am and exit between 3:00pm – 12:00am Midnight)		
Early Bird Rate	\$12.00	Maximum
Evening Rate: Monday to Thursday (Entry after 6pm and exit before 6am)		
Night Rate	\$11.00	
Weekend Rate: Per exit, per day (from 6:00pm Friday to 6:00am Monday)		
Weekend Rate	\$13.00	Per exit, per day

The Melbourne Exhibition Centre Basement Car Park has a number of ticketing pay machines located within the Car park adjacent to Entry Doors 1, 6, 8 and 10. Any enquiries please call the Wilson Car Park office (03) 9224 0301 or email to Wilson_mel197@bigpond.com.

1.1.2 FREEWAY CAR PARK RATES

FREEWAY CAR PARK		
Located at Munro Street under the Westgate Bridge. Access via Normanby Road and Munro Street		
0 - 1 hour	\$4.00	
1 - 2 hours	\$8.00	
2 - 3 hours	\$12.00	
3 - 4 hours	\$16.00	
4 - 5 hours	\$20.00	
5 - 6 hours	\$24.00	

6 hours +	\$28.00	Maximum
Lost Ticket fee	\$50.00	
Evening Rate: Entry after 6pm and exit before 6 am the next day		
Flat Rate	\$8.00	

NOTE: All Exhibitors are encouraged to use this car park.

1.1.3 SOUTH WHARF RETAIL CAR PARK RATES

SOUTH WHARF RETAIL CAR PARK Enter via Normanby Road - 24 hour Operation		
0 - 1 hour	\$4.00	
1 - 2 hours	\$8.00	
2 - 3 hours	\$12.00	
3 - 4 hours	\$16.00	
4 - 5 hours	\$20.00	
5 - 6 hours	\$24.00	
6 hours +	\$28.00	Maximum
Lost Ticket fee	\$50.00	
Evening Rate: Entry after 6pm and exit before 6 am the next day		
Flat Rate	\$8.00	

Prices are subject to change without notice.

1.1.4 MELBOURNE CONVENTION CENTRE / SIDDELEY STREET CAR PARK RATES

MELBOURNE CONVENTION CENTRE CAR PARK Enter via Siddeley Street – 24 Hour Operation		
Casual Rates: Monday to Friday (enter between 6am – 4pm)		
Per hour (or part thereof) for the first three hours	\$8.00	
For each additional hour (or part thereof)	\$4.00	
Evening Flat Rate: Monday to Friday (enter after 4:00pm and exit before 6:00am next day)		
Flat Rate	\$5.00	

Early Bird: Monday to Friday (entry between 6:00am – 9:00am and exit between 12pm & Midnight)		
Early Bird Rate	\$11.00	
Saturday, Sunday & Public Holidays (enter and exit between 6am & 6am next day)		
	\$5.00	

1.1.5 CORNER OF MONTAGUE AND MUNRO STREETS CAR PARK RATES

CORNER OF MONTAGUE AND MUNRO STREETS CAR PARK (PAY & DISPLAY) Enter via Munro Street		
Single Exit Tickets	\$5.00 for 12 hours	Per 12 hours
Prices are inclusive of GST		

Pay and Display ticketing machines are available for issue of valid parking tickets. Correct change is required for these units. Please note that the Melbourne Convention and Exhibition Centre and its car parks are "gazetted" areas with City of Melbourne parking infringements applying.

1.2 MELBOURNE CONVENTION AND EXHIBITION CENTRE LOCATION MAP



1.2.1 CAR PARKS

- MEC Basement Car Park - Enter via Normanby Road
- Freeway Car Park - Enter via Munro Street
- South Wharf Retail Car Park - Enter via Normanby Road
- Melbourne Convention Centre Car Park - Enter via Siddeley Street (not included in map above)
- Corner of Montague and Munro Streets Car Park - Enter via Munro St.

1.3 DELIVERIES

1.3.1 MELBOURNE CONVENTION AND EXHIBITION CENTRE LOADING DOCK

Melbourne Convention and Exhibition Centre
Exhibition Centre building entrance, and
Convention Centre building entrance
Loading Dock – enter off Normanby Road
South Wharf Victoria 3006 Australia

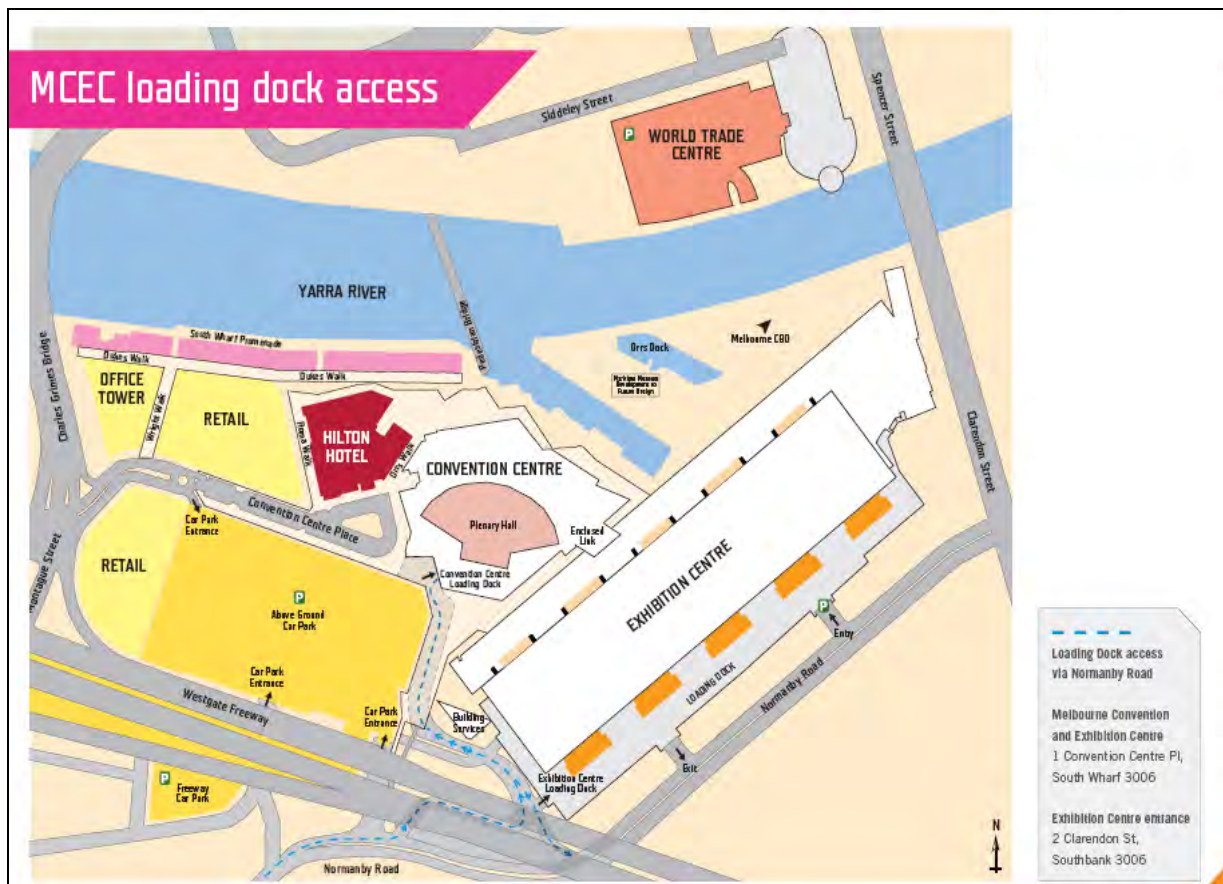

1.3.2 MELBOURNE CONVENTION AND EXHIBITION CENTRE LOADING DOCKS SPECIAL REQUIREMENTS

The Melbourne Exhibition Centre Loading Dock is a Self-Servicing Loading Dock. Refer to your organiser for details of the appointed freight handling company.

The MCEC will not sign possession of goods from couriers on behalf of exhibitors or clients. To avoid issues with the delivery of your goods always ensure that a representative is on site to take possession of these goods. Goods must not be sent to either Loading Dock before the scheduled times for the move-in of your event. All goods must be collected by the end of the official move-out time.

1.3.3 MELBOURNE CONVENTION AND EXHIBITION CENTRE LOADING DOCK SERVICES

The following services are provided:

STORAGE – MELBOURNE EXHIBITION CENTRE

Shipping Containers freighted to the Melbourne Exhibition Centre Loading Dock can only be done by prior arrangement. Please contact Melbourne Exhibition Centre Loading Dock staff on (03) 9235 8385, thirty (30) working days prior to the container arriving at the Melbourne Exhibition Centre.

Storage charge is \$60.00 per day per container including GST. Prior booking is essential as space is limited.

Trailers – Truck storage is available subject to availability. Charges do apply. Please contact the Loading Dock office on (03) 9235 8385.

STORAGE – MELBOURNE CONVENTION CENTRE

There is no storage available for exhibitors at the Melbourne Convention Centre. All enquiries must be directed to your Event Organiser or contact the Loading Dock Office on (03) 9235 8385.

LOADING DOCK ACCESS – MELBOURNE EXHIBITION CENTRE

All vehicles entering the Melbourne Exhibition Centre Loading Dock will be issued a 30-minute unloading permit. Parking infringements will be issued by authorised officers of the City of Melbourne for those vehicles exceeding the 30 minute unloading rule.

LOADING DOCK ACCESS – MELBOURNE CONVENTION CENTRE

All vehicles entering the Melbourne Convention Centre Loading Dock will be issued a 30-minute unloading permit. Parking infringements will be issued by authorised officers of the City of Melbourne for those vehicles exceeding the 30 minute unloading rule.

1.3.4 LOADING DOCKS DELIVERY LABEL

Goods will not be accepted unless the building facility below is identified.

DELIVERING TO WHICH BUILDING:	<p>EXHIBITION CENTRE BUILDING Melbourne Convention and Exhibition Centre Exhibition Centre entrance Loading Dock – enter off Normanby Road South Wharf Victoria 3006 Australia</p>
	<p>OR</p> <p>CONVENTION CENTRE BUILDING Melbourne Convention and Exhibition Centre Convention Centre entrance Loading Dock – enter off Normanby Road South Wharf Victoria 3006 Australia</p>
YOUR CONTACT NAME:	
YOUR CONTACT PHONE NUMBER:	
NAME OF EVENT:	
DATE OF EVENT:	
ROOM / AREA FOR DELIVERY:	
STAND NAME:	
STAND NUMBER:	
TOTAL NUMBER OF ITEMS:	
ITEM NUMBER:	
<p>NOTE: The Melbourne Convention and Exhibition Centre staff will not accept pre deliveries outside the commencement of the event. Please arrange with your courier and or freight forwarder or freight company to deliver only during the licensed event period.</p>	



1.4 EXHIBITS REQUIRING APPROVAL

Exhibitor displays that include animals, helium balloons or food tastings as part of their exhibit are required to submit a proposal in writing to the Melbourne Convention and Exhibition Centre briefly outlining the purpose of the display and how it will be used. Please refer to the following procedures as a guideline.

1.4.1 ANIMALS

No animals or pets, with the exception of Seeing Eye dogs, are permitted in the Melbourne Convention and Exhibition Centre except as an approved exhibit, activity or performance legitimately requiring the use of animals. All animals permitted in the licensed area must be on a leash or in an enclosed pen under the control of a handler at all times and must comply with all the requirements prescribed by law for the exhibition of such animals and in compliance with the Prevention of Cruelty to Animals Act 1986. MCEC approval is required if you wish to use animals in your exhibit.

1.4.2 HELIUM BALLOONS

Exhibitors planning to use helium balloons as part of their exhibit are required to obtain MCEC approval. There is a minimum charge of \$330 to retrieve loose balloons from the Melbourne Exhibition Centre exhibition hall ceiling.

1.4.3 TOBACCO SAMPLES

Tobacco display, sales or samples are not permitted within the MCEC. The MCEC is a smoke free venue.

1.4.4 STANDS REQUIRING ADDITIONAL SAFETY PRECAUTIONS

Should your exhibit feature any of the items listed below please contact your Exhibition Organiser for further information on the safety steps you may need to take, or written approvals that you may need to gain:

- A second storey: Certification by an engineer is required for stands of two storeys or more where the second or subsequent storey will be occupied. A Form 11, approving the design of the structure must be lodged with the MCEC before construction begins. When construction is completed an Engineer must certify the structure by completing a Form 12, a copy of which shall be forwarded to the Event Services Manager. Where a stand is erected on Centre property that requires certification, as described above or a stand with a roof area greater than 18 m² and more than 3 metres in width, the person responsible must:
 - Install smoke detectors of the type, which comply with Australian Standard AS 3786-1993 and relevant amendments.
 - Install fire extinguishers which are of the A:B:(E) dry powder type. This extinguisher is safe to use in an environment where electricity may be present.

The size and number will be specified by MCEC Management at the time and will correspond to the fire load present.

- A solid ceiling or roof area more than 18 square metres.
- A structure more than 3 metres high.
- A motor vehicle.
- Dangerous Goods as listed in the Dangerous Goods (Storage and Handling) Regulations 2000.
- A discharge of noxious waste.
- A LPG gas cylinder and overnight storage requirements.
- A cylinder containing compressed gas.
- A naked flame (e.g. a candle).
- Lighting lower than 2.2 metres above floor level. All portable light fittings used in the MCEC are required to have Certificate of Approval or Suitability from an Australian or New Zealand Electrical Safety Regulator.

1.4.5 STAND MATERIALS

Materials used in stand construction must not cause dampness or stain or be readily ignitable or be capable of emitting toxic fumes should ignition occur. Crepe paper, corrugated cardboard, straw, hay, untreated Hessian, untreated material fabrics or PVC sheet (except on floors as a protective membrane) is strictly forbidden without the express approval of the Licensor. Sawdust, tan bark or wood chips of reasonable size may be used to decorate floors, provided a protective membrane is laid first and chips are kept slightly moist at all times.

Any fabric used in the construction or decoration of a stand, including the stand ceiling, must be treated with a fire retardant. MCEC management will require proof of treatment.

Moving machinery or equipment likely to injure a member of the public or a swimming pool containing water, must be separated from the public by a physical barrier and supervised.

Provided that suitable and adequate provision is made to prevent water leaking onto the floor and the floor is otherwise protected, a Licensee may permit an exhibitor to display fountains, aquariums, spas, rock pools and swimming pools in the licensed area.

NOTE: NO CORE DRILLING OR FIXING INTO ANY FLOOR IS PERMITTED.

1.4.6 STAND FLOORING

As per the MEC Exhibition Stand Guidelines:

- A stand may have up to a 32mm high lip without bevelling
- Between 32mm and 115mm, bevelling of the edge must occur. This bevelling must not exceed an angle of 30 degrees or a grading of 1:1.4. This bevelling is to be incorporated within the stand space and not encroach out into the aisle way.

- All flooring that is over 115mm is classed as a step and if the public requires access, a wheelchair ramp needs to be installed, with a 1 metre high hand rail.

1.4.7 STAND VISIBILITY

MCEC requires that stands are open for visual inspection at all times. No stands are to be enclosed by any fabric or material at any time.

1.4.8 LIGHTING

All lighting must be 2.2 meters above the floor level. Any variation must be approved.

High-powered lights such as floods or spots must not be placed within 500mm of flammable material. All portable light fittings must have a Certificate of Suitability or a Certificate of Approval from Australian or New Zealand Electrical Safety Regulators.

1.4.9 NAKED FLAME

Proposals for the use of naked flame on stands must be submitted to the MCEC Management thirty (30) days prior to the commencement of the event. Naked flames include the use of cooking equipment, barbeques, heaters, candles, oil burners etc.

Stands using naked flames shall abide by the following instructions:

- A fire extinguisher and/or a fire blanket shall be kept on the stand in an area accessible to the general public. This fire extinguisher shall be properly signed.
- Under no circumstances will the stand be left unattended while the flame is alight.
- No flammable material shall be within one metre of the flame.
- Flames shall be extinguished 15 minutes prior to the stand being vacated at the end of the day.
- Flames will be situated so that members of the public cannot come into contact with the flame or any surface likely to burn the person or ignite their clothing.
- Facilities used for cooking must have an automatic emergency cut-off switch.
- Appropriate first aid equipment/items must be in place.

1.4.10 DISPLAYING MOTOR VEHICLES

Motor vehicles powered by flammable liquid and/or gas, may be displayed under the following conditions:

1.4.11 FLAMMABLE LIQUID POWERED MOTOR VEHICLES

The fuel tank to contain more than 90% of the fuel capacity. The motor vehicle fuel filler cap must be either sealed or secured to prevent the easy removal of the fuel cap by unauthorised persons.

UNDER NO CIRCUMSTANCES IS FUEL TO BE DECANTED OR VEHICLES FILLED ON THE MCEC LOADING DOCKS.

1.4.12 FLAMMABLE GAS (LPG) POWERED MOTOR VEHICLES

LPG powered motor vehicles must have their systems fitted in accordance with AS/NZS1425:2007 LPG Gas Fuel Systems for Vehicle Engines. The LPG fuel tank must be isolated from the engine mechanically by closing the „Service Tap’ on the fitted fuel tank.

Motor vehicles powered by flammable liquid and/or gas, may be displayed under the following conditions:

- LPG powered motor vehicles must have their systems fitted in accordance with AS/NZS1425:2007 LPG Gas Fuel Systems for Vehicle Engines.
- The LPG fuel tank must be isolated from the engine mechanically by closing the „Service Tap’ on the fitted fuel tank.
- The motor vehicles engine is to be run until all fuel in the fuel line and converter is exhausted.
- Vehicles in exhibitions will not be started and run without the prior permission of the MCEC Management. To grant permission the MCEC Management will review safety precautions and the control of exhaust emissions. All such requests shall be made in writing.

1.4.13 PORTABLE FIRE EXTINGUISHERS

For every stand that has a motor vehicle(s), the following will be the minimum equipment recommendations.

Up to three (3) motor vehicles per stand:

- 1 X 2.3kg, A:B:(E) dry powder extinguisher mounted in a prominent location in accordance with AS 2444:2001 Portable Fire Extinguishers.

Four (4) or more motor vehicles per stand:

- 2 X 2.3kg, A:B:(E) dry powder extinguishers mounted in a prominent location in accordance with AS 2444:2001 Portable Fire Extinguishers.

Nine (9) litre foam extinguishers to be strategically located so as to be available to a section (or group) of stands which have motor vehicles on display.

The foam extinguishers are for use on flammable liquids spilt on the floor of the MCEC. These extinguishers can be hired from fire safety equipment suppliers.

IGNITION KEYS ARE NOT TO BE LEFT IN THE VEHICLE AND ARE TO BE STRICTLY CONTROLLED BY THE EXHIBITOR DURING THE EXHIBITION.

1.4.14 LP GAS CYLINDERS

Exhibitions requiring the use of gas cylinders must submit full details to the Event Operations Department One week prior to the commencement of the exhibition. Each application is assessed with the safety of the public as its prime pre-requisite. The MCEC reserves the right to accept or reject any application.

Gas cylinders delivered onsite may be refused if the delivery was done without prior approval or if the representative of the exhibitor in attendance is not present to accept the cylinders.

Liquid Petroleum Gas (LPG) cylinders shall not exceed 9 Kg in size. Maximum of 2 per stand.

The installation and use of Gas Appliances and Gas Cylinders shall be undertaken in accordance with:

- Australian Standard AS/NZS 1596:2008 The Storage and Handling of LPG Gas
- AS 5601-2004 - Gas Installations

1.4.14.1 Storage of LP Gas Cylinders

All gas cylinders are to be removed from the building and returned each day.

Melbourne Exhibition Centre:

All LP gas cylinders are to be removed from the exhibition area overnight. The Melbourne Exhibition Centre has a gas cage located on the Loading Dock for the storage of gas cylinders overnight. Storage may be booked through the MCEC Loading Dock Manager.

1.4.15 CHILDREN ON SITE OUTSIDE SHOW OPEN HOURS

Any person under the age of 15 years is prohibited from accessing MCEC exhibition halls during move in and move out periods.

Persons under the age of 15 years are not permitted on the MCEC loading docks without adult supervision at all times.

1.4.16 TESTING AND TAGGING

It is a legal requirement in all temporary Exhibition work sites that all electrical equipment be tested and tagged. This applies to all contractors working on site and exhibitors who bring in electrical leads and appliances for their stands during exhibitions.

1.4.17 SAFETY VESTS

Due to an increased awareness from WorkSafe Victoria it is now mandatory for all exhibitors during move – in and out periods, to wear approved safety vests at all times.

Exhibitors and contractors will not be allowed entry to the exhibition floor unless safety vests are worn. Please contact your event organiser for further details.

1.5 FOOD AND BEVERAGE SAMPLING

1.5.1 FOOD AND BEVERAGE SAMPLING WITHIN VICTORIA

The Victorian State government food and Liquor regulations that cover all distribution of food and beverage products will continue to be applied to all events held at the Melbourne Convention and Exhibition Centre.

The MCEC has exclusive rights for the sale and distribution of all food and drink. No exhibitor or person shall distribute, sell or give away any item of food or drink to visitors to the MCEC without the prior written approval of the MCET. Generally, MCEC management will not object to the distribution by exhibitors of food items, used as a means of demonstrating any product manufactured or supplied by the exhibitor, forming part of an exhibition. However the sale of such products is not permitted.

Please submit all venue approval proposals to exservices@mcec.com.au detailing the item/s, quantities, and relation to the core business.

As a rule, guidelines for the distribution of sample servings of food or beverages are as follows:

- All Exhibitors wishing to distribute food or beverage must register a temporary food premises with the Melbourne City Council.
- Samples must be given away free of cost.
- Such samples must be items that registered exhibitors wholesale in the normal conduct of their business or are produced by equipment used in the normal conduct of their business.
- Exhibitors must obtain a Limited Liquor Licence from the Office of Director of Liquor Licensing in Victoria if they wish to provide alcoholic samples. Ph 1300 650 367
- Sample portions must be of a tasting style and size only - no larger than 50ml.
- Sampling of alcoholic product can be conducted in the licensed area only.
- Extra cleaning charges incurred through spillage or the removal of food or wet waste will be the responsibility of the Exhibitor.

The Victorian state government food and liquor regulations require stands handling and serving food or beverage, to have washing facilities on their exhibition stand. Exhibitors can provide their own licensed plumber for connection of sinks and hot water services. If you require the services of a licensed plumber we would be happy to suggest a licensed plumber that you can contact directly. Please telephone Exhibitor Services on (03) 9235 8110.

1.5.2 IMPORTANT NOTE:

Beverage products are considered by the Melbourne City Council to be foodstuffs when dealing in the context of Food Handling and Safety and the issuance of temporary food premise licences. The MCEC has an expectation that all exhibitors

will contact the Melbourne City Council in advance of their event to determine the Food Safety and Handling requirements for their beverage product(s).

1.5.3 ALCOHOL BEVERAGE SAMPLING

The Victorian Liquor Control Reform Act 1998 is the relevant legislation that covers the liquor licensing requirements for beverage samples. For one off or short-term events, where the serving of alcoholic samples is proposed, a Limited Licence must be obtained (See attached application form below), or visit the Victorian Liquor Licensing website www.justice.gov.au for further information or to download the application form in PDF format).

Please note that applications for limited licences should be lodged at least 35 days before the event commences. In some cases, you may be required to provide further information or a floor plan of the premises, or to publicly display a notice of the application.

The City of Melbourne Health Services Branch has provided the following guidelines for “Temporary Food Premises Operating at Special Events.” For further information and to obtain a registration form please telephone the City of Melbourne on (03) 9658 8831.

1.5.4 HEALTH ACT REQUIREMENTS

Any exhibitor or person carrying out practices such as body piercing, tattooing, application of makeup, hairdressing, etc. to visitors to the MCEC, requires a Temporary Health Act Registration with the City of Melbourne.

Event organisers (and/or Exhibitors) should contact the City of Melbourne Health Services Branch on (03) 9658 8831 as early as possible prior to the event in order to ensure that any of the above practices carried out by exhibitors do not pose a risk to public safety.

An application form must be completed by each applicant and returned to the City of Melbourne Health Services Branch at least 14 days prior to the date of the event. A registration fee negotiated between the City of Melbourne and the event organiser must be accompanied with each application, also prior to the date of the event. This fee is to be paid directly to the City of Melbourne Health Services Branch 2 weeks prior to the event. However if the proceeds from the operation of the stalls are to be donated to a charitable organisation running the event, this fee is not applicable.

A site plan of the location of each stall is also required to be returned to this office. These details are crucial to the development of the health inspection and monitoring program for the event.

1.5.5 ALCOHOL SALES/CONSUMPTION DURING MOVE IN/MOVE OUT

As part of the Melbourne Convention and Exhibition Centre continuous improvement policy for the management of Occupational Health and Safety there is a restriction on the sale and consumption of alcohol during move in - out periods of exhibitions.

A SafetyMAP Internal Audit highlighted concerns over alcohol and the operation of plant and equipment during move in/out. In response to this highlighted risk, no alcoholic beverages will be sold or served by the Melbourne Convention and Exhibition Centre via our kiosks and Stand Catering services during designated move-in and move-out periods.

1.6 EXHIBITION HALL DETAILS

The Melbourne Exhibition Centre has twenty (20) bays of exhibition space with a total floor area of 30,000 sqm. The floor area of each bay is 1,500 sqm. Maximum size hall is 30,000 sqm and the minimum size of tenancy is 3,000 sqm. Four operable walls can be placed in 13 locations to provide five areas of different sizes.

Clear height below trusses in the hall is 11.5m. The maximum clearance between trusses and the hall floor is 18m.

1.8 UTILITY SERVICES

It is the responsibility of the exhibitor to arrange connection from the service pit to equipment. If you require the services of a licensed plumber we would be happy to suggest a licensed plumber that you can contact directly. Please telephone Exhibitor Services on (03) 9235 8110.

Pit access fees specifically fund the cost of regular site service inspections to ensure the industry's best practice and safety standards have been applied. The fee, \$38.50, applies to access only. It does not include connection of equipment to outlet.

All contractors, service technicians, tradespeople and exhibitor personnel who work in the Melbourne Convention and Exhibition Centre are required to adhere to all relevant Australian Standards, perform their tasks within set Industry Codes of Practice and hold all necessary licences. (Apprentices must be supervised). All wastewater must be discharged into a Melbourne Water sewer, in accordance with Melbourne Water By-Laws (Melbourne metro area) or discharged in accordance with local statutory laws.

1.8.1 MELBOURNE EXHIBITION CENTRE – FITTINGS

Cold water and waste systems are provided for use by exhibitors with outlets in each of the primary floor pits. Water is provided at a flow rate of 0.3 L/s in each primary floor pit and a waste outlet with a discharge rate of 6 L/s is also provided. If water is required at a greater flow rate, the operator may connect to more than one service pit, i.e. use two or three hoses.

Exhibitors requiring hose connections for water will need to provide a pressure hose (domestic garden hoses are not permitted) and a (15mm) ½" female threaded BSP fitting. A drain with grate is provided in the primary service pits. To connect to waste disposal exhibitors require a 40mm diameter BSP female socket. To connect to compressed air supply, exhibitors require a 15mm (½") male connector to match a 15mm (female outlet) ball valve. Compressed air is of normal industrial quality. Regulators, filters and lubricators are to be provided by the exhibitor as required. The Melbourne Exhibition Centre can provide 25L/s (normal air @ 02-3C, 7 Bar pressure) to any 5000 sqm. exhibition space. Should a larger flow rate be required please telephone Exhibitor Services on (03) 9235 8110 two weeks prior to the event.

Exhibitors must provide their own licensed plumber for connection from the service pit to their equipment.

1.8.2 WASHING FACILITIES ON STANDS

The Victorian state government food and liquor regulations require stands handling and serving food or beverage, to have washing facilities on their exhibition stand. Exhibitors can provide their own licensed plumber for connection of sinks and hot

water services. If you require the services of a licensed plumber we would be happy to suggest a licensed plumber that you can contact directly. Please telephone Exhibitor Services on (03) 9235 8110.

1.9 TRADE PROMOTION LOTTERY

1.9.1 INFORMATION ON THE CONDUCT OF A TRADE PROMOTION LOTTERY THAT HAS A TOTAL RETAIL PRIZE VALUE OF \$5000 OR LESS:

This type of trade promotion lottery does not require a permit.

No fee shall be required from any person for the right to participate in the lottery. This does not prevent a person from being required to purchase a genuine product or service to be eligible to enter. In addition, no participant can be required to incur a cost of more than 55 cents to enter. (This is to cover postage or a telephone call – it cannot be an entry fee)

(If the individual value of a prize in the lottery exceeds \$250 the name of the winner must be published in a newspaper circulating generally in Victoria. However, if the total value of prizes for the lottery is less than \$500 but an individual prize exceeds \$250, the name of the winner only needs to be published in a newspaper circulating generally in the area.

The winner(s) must be notified in writing.

All entry forms and promotional material must include:

- i) the closing date of the lottery, and
- ii) when and where the lottery will be drawn, and
- iii) the means by which the winner will be notified; and
- iv) the conditions of entry if any.

Entrants in a lottery must not be required to be present at the drawing of the lottery to be eligible to participate, unless the draw is to take place within 24 hours of commencement and the only means of entry is at the premises where the draw will take place. e.g. at a trade expo and the draw will be conducted at the conclusion of the day.

For any further information please contact the Minor Gaming Unit, Victorian Commission for Gambling Regulation on 03 9651 3630 or by email at minor.gaming@vcgr.vic.gov.au. Further information and applications forms if required can be found on Victorian Government website at www.vcgr.vic.gov.au.

1.9.2 IMPORTANT NOTICE

A permit must be obtained from the Director of Gaming and Betting to conduct a Trade Promotion Lottery in Victoria where the total retail value of the prize/s exceed \$5000.

SECTION 2: SERVICE ORDER FORMS

MCEC SERVICE ORDER FORMS:

- 1. Return all relevant Service Order Forms to:**
Exhibitor Services Department via facsimile: +61 3 9235 8121

Completed order forms with payment should be returned to:
Melbourne Convention and Exhibition Centre
Exhibitor Services
GPO Box 777
Melbourne Victoria
Australia 3001
Tel: (03) 9235 8110
Fax: (03) 9235 8121

- 2. All prices are inclusive of GST.**

2.1 EXHIBITOR SERVICES ACCOUNT FORM

Name of Event:		
Event Dates:		
Stand Name:		
Stand No.:		
Company:		
Contact Name:		
Position:		
Address:		
	State:	Post Code:
Telephone:	Facsimile:	
Mobile:	E-Mail:	

Please indicate your requirements on the following pages and return this form and all relevant order forms, no later than seven (7) days prior to the commencement of the event.

Please return your completed forms to fax number +61 3 9235 8121 or email forms to exservices@mcec.com.au .

Once your order has been received and processed, you will be sent a Proforma Tax Invoice and Payment Authorisation Form confirming your order details. Please complete the Payment Authorisation Form and return via fax to +61 2 9235 8071 or email to remittance@mcec.com.au . No services will be provided until payment is received.

All service charges are current and subject to change without notice.

Information Privacy Act 2000 – Information collected on this form will only be used for the completion of this enquiry.

The Melbourne Convention and Exhibition Trust (MCET) Privacy Policy is available from our web site www.mcec.com.au , Reception or Customer Service.

Advised of MCET Privacy Policy: YES NO

I hereby give my consent to use and disclose information on this form in accordance with the advised Use and Disclosure Statement. I have been advised of the MCET Privacy Policy and how to obtain a copy of the policy.

Signature: _____ Date: _____



2.2 COMMUNICATIONS ORDER FORM

2.2.1 TELEPHONE SERVICES



Please indicate your requirements below and return together with the Exhibitor Services Account form to fax number +61 3 9235 8121.

Exhibitor Services Account Form has been attached

Order cannot be processed without the completed details below and the Exhibitor Services Account Form.

Please refer to the service information section below for additional details. You must sign and return this service information with your order. For additional information please contact Communication Services on (03) 9235 8160 or Email exservices@mcec.com.au .

SERVICE	PRICE (Per Event)	SERVICE DEPOSIT
DIGITAL PHONE LINE & HANDSET International Call Access Yes / No Quantity required <input type="checkbox"/> Phone lines are digital and will not work with standard analogue devices such as modems and EFTPOS machines	\$110.00 per line	\$220.00 per line <i>Includes deposit for handset.</i>
FACSIMILE LINE International Call Access Yes / No Quantity required <input type="checkbox"/>	\$110.00 per line	\$165.00 per line
EFTPOS LINE Quantity required <input type="checkbox"/>	\$110.00 per line	\$165.00 per line
DIRECT LINE (PSTN) Quantity required <input type="checkbox"/>	\$269.50 per line	N/A
ISDN ONRAMP2 (2 weeks notice required) Quantity required <input type="checkbox"/>	\$693.00 per line	N/A

2.2.2 TELEPHONE SERVICE INFORMATION

All phone, facsimile and EFTPOS connections at the MCEC require the user to dial "0" to obtain an outside line.

Digital phone handsets and equipment are delivered to stands on the last day of event move-in or earlier by request of the exhibitor.

Digital phone handsets that are issued will not work if removed from the building. Handsets will be collected at the conclusion of the event, however if you wish to leave before it has been collected please return it to Customer Service or call on (03) 9235 8302 for it to be collected. Lost or damaged handsets will be charged at up to \$450.00.

A call deposit is required for each line to cover call charges and for loss of equipment. The unused portion is refundable after the conclusion of the event when the charges have been calculated. Please note that a receipt of call charges may take up to 2 weeks post event.

All phone and fax lines are enabled with LOCAL, STD, IDD and MOBILE call access unless specified otherwise.

Exhibitors requiring ISDN Onramp 2 Services are required to book 2 weeks prior to the delivery date.

Exhibitors are advised that the ISDN Onramp2 connection is inclusive of the Network Terminating Unit but does not include an ISDN Terminal Adapter or Router. Exhibitors wishing to use the OnRamp2 service are required to provide their own ISDN Terminal Adapter or Router.

All calls made from the MCEC are charged at the following rates. International calls will be charged at the carrier rates applicable at the time of the event and will be settled after the event when the call details are available.

Exhibitors are required to arrange their own EFTPOS Machine. This can be obtained from their Bank or Financial Institution or alternately they can provide their own.

CALL TYPE	CALL CHARGES
Local Calls	44 cents flat rate
STD / Mobile Calls	44 cents per minute

2.2.3 WIRELESS INTERNET ACCESS

Visitors to the Melbourne Convention and Exhibition Centre will have access to free wireless internet, a first for any centre in the country. Event organisers will have the option of upgrading to a platinum wireless service designed specifically for their delegates. Your Technology Services Coordinator will be able to assist you in determining the best available solution to meet your event specific requirements.

M CONNECT - FREE Wi-Fi

This service would:

- Be shared by all conference delegates, event attendees and general public in the building during your event. This service would not be just for event delegates and is not designed to provide a guaranteed number of concurrent users for a particular event in a particular location.
- Have a maximum bandwidth of 256Kb/s*. The actual bandwidth will be influenced by the number and density of concurrent users.
- Require individual users to subscribe (free of charge) to the service via a login page agreeing to a set of terms and conditions**. Individual users will need to re-subscribe (free of charge) to the service after 12 hours or once the 100MB download limit is reached.
- Be delivered by in-house wireless access points (WAPs) and provide coverage extending throughout the venue including meeting rooms, exhibition bays, the Plenary and all other public spaces.
- Be suitable for web based email, Facebook, Twitter and basic internet browsing. This service does support applications such as Skype, streaming video, VPN connections and peer to peer file sharing.

M CONNECT - PLATINUM Wi-Fi .

This service would:

- Be specifically for your conference delegates.
- Allow unrestricted internet access*** with increased bandwidth for individual users.
- Allow for a custom SSID with your event name and a custom authentication method.
- Be tailored to meet the needs of your event in terms of coverage, speed (bandwidth) as well as the number and density of concurrent users.
- Be delivered by in-house wireless access points (WAPs), augmented with event specific high density WAPs deployed at required locations for the duration of the event.
- Be suitable for running internet based workshops in rooms.
- Include generous download allowances.

The cost for this service would depend upon your specific event requirement.

PLEASE NOTE:

* Wireless is a less secure service and download speeds will vary depending on the number of users on the service at any one time. Wireless signal strength can also vary depending on geographical location and other items interfering with the signal. For best results we recommend the use of 5GHz (IEEE 802.11n-2009 standard) wireless compatible devices. Previous standards are supported but results can vary in line with the inherent limitations of these standards and associated devices.

Clients who require a secure network to download continuous information over a longer period of time are advised to order a dedicated fixed-line service.

** A full set of MCEC Wireless Terms of Use are available from the MCEC Wireless portal. <http://www.mcec.com.au/Utility/MCEC-Information/wireless-terms.html>

***Consideration may need to be made in relation to access of peer to peer file sharing sites as excessive downloads and reduced bandwidth have been experienced on some events.

BROADBAND INTERNET

Highspeed broadband (cabled) Internet access can be provided to any room in the venue. This includes the Exhibition Centre bays and Convention Centre foyers.

Services range in price depending upon the duration the service is provided and the required bandwidth. The following table provides a sample of services available. Custom services can be provided to meet larger bandwidth or download requirements.

INTERNET SERVICE AND BANDWIDTH	INCLUDED DOWNLOAD ALLOWANCE	SERVICE DURATION OPTIONS
Broadband Internet – 256 Kbps	1GB	1-7 Days or 8-14 Days
Broadband Internet – 512 Kbps	1.5GB	1-7 Days or 8-14 Days
Broadband Internet – 1 Mbps	2GB	1-7 Days or 8-14 Days
Broadband Internet – 2 Mbps	4GB	1-7 Days or 8-14 Days
Broadband Internet – 6 Mbps	8GB	1-7 Days or 8-14 Days
Broadband Internet – 10 Mbps	10GB	1-7 Days or 8-14 Days

The following address will allow you to periodically check your usage. Simply enter the address provided below whilst you are connected to your MCEC Broadband service. <http://internet.mcec.com.au:7011/myUsage>.

Once your download allowance is reached, excess data is charged at 10c per Mb.

PLEASE NOTE:

The MCEC will not manage, monitor or support any third party devices connected to our network such as network switches, routers or wireless routers. Should it be discovered that these devices pose either a security risk to the MCEC network or create network issues we will be forced to disconnect, remove or disable any such devices in order to ensure the integrity of the network for both the venue and for other clients relying upon the infrastructure.

2.2.4 BROADBAND INTERNET ACCESS



Please indicate your requirements below and return together with the Exhibitor Services Account form to fax number +61 3 9235 8121.

Order cannot be processed without the completed details below and the Exhibitor Services Account Form.

Please refer to the Service Information section below for additional details. You must sign and return this information with your orders. For additional information please contact Communication Services on (03) 9235 8160 or Email TSDSales@mcec.com.au

SERVICE	1 - 7 DAY PRICE	7 – 14 DAY PRICE
BROADBAND INTERNET– 256 Kbps (1Gb download Included) 1 cable for 1 computer – Private IP address assigned as standard. Additional connections must be ordered on the following page to connect more than one computer.	\$270.00 <input type="checkbox"/>	\$520.00 <input type="checkbox"/>
BROADBAND INTERNET – 512 Kbps (1.5Gb download included) 1 cable for 1 computer – Private IP address assigned as standard. Additional connections must be ordered on the following page to connect more than one computer.	\$330.00 <input type="checkbox"/>	\$640.00 <input type="checkbox"/>
BROADBAND INTERNET – 1 Mbps (2 Gb download included) 1 cable for 1 computer – Private IP address assigned as standard. Additional connections must be ordered on the following page to connect more than one computer.	\$455.00 <input type="checkbox"/>	\$900.00 <input type="checkbox"/>
BROADBAND INTERNET – 2 Mbps (4 Gb download included) 1 cable for 1 computer – Private IP address assigned as standard. Additional connections must be ordered on the following page to connect more than one computer.	\$900.00 <input type="checkbox"/>	\$1760.00 <input type="checkbox"/>

BROADBAND INTERNET – 6 Mbps (8 Gb download included) 1 cable for 1 computer – Private IP address assigned as standard. Additional connections must be ordered on the following page to connect more than one computer.	\$1500.00 <input type="checkbox"/>	\$3000.00 <input type="checkbox"/>
BROADBAND INTERNET – 10 Mbps (10 Gb download included) 1 cable for 1 computer – Private IP address assigned as standard. Additional connections must be ordered on the following page to connect more than one computer.	\$2200.00 <input type="checkbox"/>	\$4400.00 <input type="checkbox"/>

The following address will allow you to periodically check your usage. Simply enter the address provided below whilst you are connected to your MCEC Broadband service. <http://internet.mecc.com.au:7011/myUsage>.

Once your download allowance is reached, excess data is charged at 10c per Mb.

PLEASE NOTE: The MCEC will not manage, monitor or support any third party devices connected to our network such as network switches, routers or wireless routers. Should it be discovered that these devices pose either a security risk to the MCEC network or create network issues we will be forced to disconnect, remove or disable any such devices in order to ensure the integrity of the network for both the venue and for other clients relying upon the infrastructure.

PERIPHERAL BROADBAND SERVICES		
Private IP Addresses	COST PER CONNECTION	NUMBER OF CONNECTIONS
ADDITIONAL CONNECTION – PRIVATE IP ADDRESS WITH CABLE Required to connect an additional computer. 1 per each additional computer.	\$22.00	
Public IP Addresses	COST PER CONNECTION	NUMBER OF CONNECTIONS
ADDITIONAL CONNECTION - PUBLIC IP ADDRESS WITH CABLE See section 2.2.2.1 below. 1 per additional computer.	\$44.00	
Technical Assistance		
COMPUTER CONFIGURATION I require assistance in configuring my computer(s). Minimum Charge of half an hour.	\$35.00 per half hour	

2.2.5 ADDITIONAL CONNECTIONS

Additional IP's are required when more than one computer is to be connected to a broadband service. Irrespective of whether you are providing your own hub/switch and cables.

By default private IP's are assigned for your security, however public IP addresses are available for specific requirements. Some Virtual Private Networks (VPN) and server applications may require public IP addresses.

2.2.6 BROADBAND INTERNET ACCESS – SERVICE INFORMATION

Please note for connection to our Broadband Internet you will need to have your computer set to obtain IP and DNS addresses automatically from our DHCP server. This is the standard operating system default. Administrator access is required if you require the MCEC to configure your computer with these settings. Ideally your administrator can configure these details for you.

Broadband Internet Access price includes the internet access itself through the supplied network cable for the nominated amount of downloads. We can help you configure your computer with the appropriate settings to access our Broadband connection. For other computer related issues you should contact your administrator, computer vendor or IT support. We may be able to assist with some queries, however please note that a labour charge will be incurred and we do not take responsibility for problems with your computer.

Broadband Services do not pass through any firewalls to allow maximum access to our end users, however by default are private IP addresses which offer some protection from the outside world. Computer Security and Virus Protection remains the responsibility of the client. We recommend that virus protection with the latest virus definitions be installed and that all operating systems patches and updates also be installed. MCEC accepts no responsibility for clients computers contracting viruses or having security compromised once connected to the Internet. We will ensure that the Internet Connection is functioning correctly.

Broadband Services provided are not for resale or sharing with other exhibitors. Offenders will be disconnected and further action may be taken.

MCEC can provide you computers that have a fresh install with the latest virus definitions and windows updates installed.

2.3 COMMUNICATION LINE FLOOR PLAN

Please complete the details below and return this section with your communication order and account form either by email or fax.

Email address: exservices@mcec.com.au

Fax Number : (03) 9235 8121

DELIVERY DETAILS	
Connection Date:	/ /
Disconnection Date	/ /
Event Name:	
Stand Name:	
Stand Number:	
Custom Flooring:	YES / NO
Install Date:	/ /
Install Time:	

SERVICE LOCATION	
Please draw a representative plan of your stand and mark your ordered services on this plan. (Please show all solid walls). If you already have a floor plan please attach to this order instead.	
P = Phone Line	<i>Back Of Stand</i>
F = Fax Line	
E = EFTPos Line	
B = Broadband Line	
D = Direct Line	
I = ISDN Line	



2.6 UTILITY SERVICES

Please indicate your requirements below and return together with the Exhibitor Services Account form to fax number +61 3 9235 8121.

It is the responsibility of the exhibitor to arrange a licensed plumber for connection from the service pit to their equipment. If you require the services of a licensed plumber, we would be happy to suggest a licensed plumber that you can contact directly. Please contact Exhibitor Services on telephone (03) 9235 8110. Please refer to the Service Information section for details of fittings required.

All wastewater must be discharged into a Melbourne Water sewer, in accordance with Melbourne Water By-Laws (Melbourne metro area) or discharged in accordance with local statutory laws.

Please indicate the service required in the appropriate column:

SERVICE	ACCESS FEE PER PIT	USAGE	NO. OF SERVICES
WATER Exhibitors must provide their own licensed plumber for connection from the service pit to their equipment	\$38.50* * Access only to the service pit	\$2.20 per 1000 litres or part thereof Number of litres _____	_____
COMPRESSED AIR Exhibitors must provide their own licensed plumber for connection from the service pit to their equipment	\$38.50* * Access only to the service pit	\$22.00 per day Total number of days _____	_____

Position of Water and Compressed Air access is limited, please check with your Event Planner for location details.

Access to pits is required by: ___/___/___

Pit access fees specifically fund the cost of regular site service inspections to ensure industry best practice and safety standards have been applied. It is the responsibility of the exhibitor to arrange connection from the service pit to their equipment

If ordering compressed air access, please complete the following:

COMPRESSED AIR	
Air Flow Rate (Litres per second):	
Pressure (Kpa) :	
Event Name:	
Stand Name:	
Stand Number:	

2.7 CAPPUCCINO/ ESPRESSO MACHINE WITH A SKILLED BARISTA



Green Cup Espresso is the sole contractor for specialised espresso vending within the Melbourne Convention and Exhibition Centre.

- We have expertise in catering for both organisers and exhibitors with an extensive range of modular stainless coffee carts and new espresso machines.
- Our focus is been strongly on coffee quality as well as equitable and sustainable practices in both sourcing and consuming of espresso coffee.

All packages include locally roasted Small Batch coffee, premium hot chocolate and loose leaf Tea Drop tea. We use fully biodegradable and compostable cups. Installation of all set ups involve no additional costs.

Please visit www.greencupespresso.com.au for more information.

Standard Espresso Package (8 oz cup size):

- Skilled Barista
- \$160 per hour inclusive of GST (includes a *total average* of 50 cups per hour of operation).
- If 50 cup average is exceeded, cost is \$2.95 per cup inclusive of GST.
- Minimum 4 hours operation.
- Charged in half hour increments.

Event Espresso Package (8 oz cup size):

- Two Skilled Baristas
- \$305 per hour inclusive of GST (includes a total average of 100 cups per hour of operation).
- If 100 cup average is exceeded, cost is \$1.95 per cup inclusive of GST.
- Minimum 4 hour operation per day.
- Charged in 15 minute increments.

Additional Barista (\$39 per hour minimum 4 hours).

An Additional Barista can be added to either package and is recommended for high volume catering or added service.

Please refer to the Espresso Package Order Form on the next page.



2.7.1 ESPRESSO PACKAGE ORDER FORM

Please indicate your requirements below and return together with the Exhibitor Services Account form to fax number +61 3 9235 8121.

Event Name:	
Stand Name & No.:	
Date and Times required:	
Name:	
Contact Details:	

Please indicate your requirements with a tick or number:

Standard Espresso Package Additional Barista

OR

Event Espresso Package No. of Additional Baristas

Agree to Terms below:

- Bookings are subject to availability
- Package cannot be guaranteed unless booked at least four days prior to operation.
- An installation fee of \$55 per hour will apply if the site is not as per the specifications of the booking.
- Any damage or losses will be billed to the user.
- Stand Builder to be advised of *Stand Build Requirements*.

Require free standing coffee cart. Agree to Stand Build Requirements on the next page.

OR

Providing own bench or counter. Agree to Stand Build Requirements on the next page.

2.7.2 STAND BUILD REQUIREMENTS

Please ensure that Stand Builders receive the following requirements:

Free standing Coffee Cart

Refrigeration/ice chest will be provided.

Coffee Cart dimensions: Width 1750mm x Depth 770mm

- Cart must be placed within allocated floor space. Provide suitable workspace surrounding cart.
- Smaller and larger coffee carts are available upon request.

Power Supply: Responsibility of Stand Builder/Exhibitor to arrange.

- 20 amp power required for espresso machine (in the form of a suitable three pin socket).
- An additional regular 10 amp power source is required for the coffee grinder.
- Both power outlets are to be located directly under coffee cart.

*Event Espresso Packages suggested floor space is 3m x 3m located above 3 phase pit access.

OR

Provision of own bench or counter

A small underbench refrigerator is suggested (exhibitor to arrange) or space to allow for an ice-chest.

Minimum Bench Dimensions: Minimum Width 1740mm x Minimum Depth 700mm

Suitable storage space below cabinet is required for water bottles, waste water container and consumables: Height 750mm x Width 750mm x Depth 700mm

- Bench height should be in the vicinity of 900-950mm within OH&S requirements.
- A benchtop hole of approximately 60mm diameter in the centre of the bench for machine power cord, water pick-up hose and sillage hose.
- Benchtop or cabinet must support approximately 70kgs.

Power Supply: (Responsibility of Stand Builder/Exhibitor to arrange)

- 20 amp power required for espresso machine (in the form of a suitable three pin socket).
- An additional regular 10 amp power source required for the coffee grinder.
- Both power outlets are to be located directly under coffee bench.

2.8 STAND CATERING GUIDELINES FOR ORDERING

The Melbourne Convention and Exhibition Centre has the sole catering rights to all food and beverage products. Exhibitors are not permitted to bring food and beverage into the MCEC from outside sources. Exceptions only apply in circumstances related to food and/or beverage tastings.

Before completing your order form please read the information we have provided on Stand Catering in the service information section of this Kit. Please note that in certain circumstances minimum quantities apply.

To ensure we can accommodate your stand catering request, we require a minimum 2 working days notice. Please note that we require 72 hours notice for order cancellations. If cancellations are received after this time, the full charge will apply.

Please indicate your requirements below and return together with the Exhibitor Services Account form to fax number +61 3 9235 8121.

Order cannot be processed without the completed Stand Catering Order Form below and the Exhibitor Services Account Form.

Please note the following in relation to stand catering:

- There is a minimum order of 10 people per menu and orders placed for more than this number must be increased by increments of 10 people. For example, Menu 2 could be ordered for 20 people, but not for 15.
- The delivery time for your order must be made either on the hour or half hour. For example, an order may be placed for 9.00 am or 10.30 am, however not for 9.15am or 10.40 am.
- All stand catering is delivered and dropped off to your stand on room service trolleys and is self-served. All room service trolleys are for delivery drop offs only and are not left on stands. It is the responsibility of the exhibitor to have appropriate bench space for all their stand catering orders. MCEC does not supply furniture to stands. Please contact your stand builder or external exhibition hire company if furniture is required.
- If you require staff to service your stand, this facility can also be provided at an additional cost if 48 hours' notice is provided.
- It is the responsibility of the exhibitor to ensure all non disposable equipment is accounted for upon equipment collection from stands. The cost of any lost equipment will be on charged to the exhibitor.
- An authorised signatory **MUST** be present at the stand at all delivery times stated on the Stand Catering Order Form. (This includes bump in/out times).

The Melbourne Convention and Exhibition Centre can offer an extensive menu selection if you wish to cater for more than 50 guests. Please telephone Exhibitor Services on (03) 9235 8110 to obtain further information.



2.8.1 STAND CATERING ORDER FORM

DELIVERY DAY	DELIVERY DATE	DELIVERY TIME	MENU # or ITEM CODE	MENU DESCRIPTION	QTY	COST
TOTAL COST						\$

Please return your completed form to fax number +61 3 9235 8121 or email to exservices@mcec.com.au .



2.8.2 STAND CATERING SPECIAL ITEM QUOTATION REQUEST

If you require any food or beverage items not listed on the Stand Catering selection on the following pages please list your requirements below and provided we are able to source the item/s we will provide you with a quotation and minimum order quantity. Please contact us to discuss your requirements.

Please note that there is a minimum five (5) working days notice required prior to the event to source the quotation for any special item requests.

Please return your completed form to fax number +61 3 9235 8121 or email to exservices@mcec.com.au.

CONTACT DETAILS	
Name of Event	
Stand Name	
Stand Number	
Company Name	
Contact Name	
Contact Phone Number	
Contact Email	

ITEM REQUIRED	QUANTITY	DELIVERY DATE	DELIVERY TIME

2.9 STAND CATERING MENU SELECTION

MENU 1A – 100 Cup Hot Water Urn (Heat barrier cups) \$220.00 (per event) ** 10 amp power required	
80 Coffee Sachets	100 Stirrers
20 English Breakfast Tea / 10 Herbal Tea	120 Sugar Sticks
10 Hot Chocolate	100 Heat Barrier Cups
Milk (2 litre) <i>(Note: if you stand has no fridge, you can hire an ice bucket for \$5.00 per day. Just add the item to the Stand Catering Order Form.)</i>	

MENU 1B – 32 Cup Coffee & Tea Urn \$75.00 (per day) ** No power required	
2 x 12 Cup Urns of Freshly Brewed Coffee	24 Teaspoons
12 Cup Hot Water Thermo Unit	30 Sugar Sticks
32 Cups and Saucers	12 Tea bags (English Breakfast & Herbal)
Milk (2 litre) <i>(Note: if you stand has no fridge, you can hire an ice bucket for \$5.00 per day. Just add the item to the Stand Catering Order Form.)</i>	

Additional Stock	Cost
12 Cup Hot Water Thermo Unit with 10 Tea Bags	\$27.50
12 Cup Freshly Brewed Coffee	\$27.50

Replenishment Stock	Cost
Assorted Nespresso Pods (refer to next page Menu 1C for Nespresso Pod flavours)	\$3.20 ea
50 Cups and Saucers (teaspoons also supplied)	\$50.00
10 Cups and Saucers (teaspoons also supplied)	\$10.00
10 Coffee Sachets	\$15.00
10 Tea Bags	\$17.50
10 Hot Chocolate	\$17.50
2 Litres Milk	\$5.00
1 Litre Soy Milk	\$4.00
Ice Bucket Hire – (for milk) <i>Holds a maximum of 2 x 2L bottles</i>	\$5.00 ea – per day
Sugar / Stirrers (with order)	FOC
Disposable Black Ripple Heat Barrier Cups - Qty 50	\$12.00

<p>MENU 1C – Nespresso Machine Semi Automatic \$175.00 per event **Bookings are subject to availability**</p>
<p>To offer the perfect espresso coffee on your stand for your customers and delegates. This machine is suitable for up to 100 cups per day.</p>
<p>Package includes – 30 Nespresso coffee pods, 10 Tea Bags, 10 Hot Chocolates, 50 Black Ripple Heat Barrier Cups, 50 Wooden Stirrers, Sugar and 2 litres milk.</p>
<p>Additional Nespresso Pods are available upon request as per the replenishment stock list on the previous page.</p>
<p>IMPORTANT NOTE: On your Stand Catering Order Form please specify a time for each day you would like MCEC staff at your stand to set your machine ready for use. If the machine will be in a locked area of your stand, please indicate a time when your stand will be manned to provide access for a MCEC staff member. Milk that has been in canister during the day cannot be put in fridge overnight and re used the next day. You will need to order fresh milk everyday (\$5 for 2L) at the same time you require your machine set up.</p>

Power and Dimensions of the Nespresso Machine	
<ul style="list-style-type: none"> • 10 amp power required • Width of machine: 560mm 	<ul style="list-style-type: none"> • Height of machine: 370mm • Depth of machine: 392mm

Nespresso Machine:



<p>Nespresso Pod – Flavours Please specify on order form if anything in particular is required . Amounts over what is included in package (30) will be charged at \$3.20 per pod -Strongest (1) -Weakest (4)</p>
<p>(1) Ristretto Connoisseurs of Italian Espresso will appreciate the intense body and remarkable lingering taste of this Grand Cru. Composed exclusively of Latin American Arabicas, Ristretto cloaks its strong personality with dense and smooth crema.</p>
<p>(2) Espresso Forte This is a round and balanced espresso combining intense body with great aromatic richness. It is savoured strong with a drop of milk froth for a touch of sweetness, if one desires.</p>

<p>(3) Caffe Forte Blended exclusively from the best Arabicas the American continent has to offer, the caffe forte Lungo is dense and Velvety, rich and Intense. It is served in a large cup with or without milk</p>
<p>(4) Decaffeinato Decaffeinato is balance and fresh blend of naturally decaffeinated Arabicas and Robusta from South America. Subtle and mild.</p>

Operational Information: (Functionalities)

Fresh Milk is stored in a 1 litre thermal container which remains cold for up to 8 hours. Frothing or steaming milk with a simple press of a button, takes approximately 20 seconds. The semi – automatic pod insertion and ejection assists with the cleanliness and daily maintenance of the machine. With the innovative double head extraction system, it can prepare two coffees simultaneously. It also includes a hot water dispenser, and contains removable water tanks (2 x 3 litres each).

ALL DAY BREAKFAST

MENU 2 – Breakfast Package \$82.00 per 10 pax - 30 pieces
Danish pastries, croissants, banana bread served with maple butter
Minimum 10 people / Maximum 50 People

MENU #	Additional Breakfast Items	Cost
2A	Egg and bacon muffins	\$45 for 10 people
2B	Toasted fruit and nut muesli cup with vanilla yoghurt and fresh fruit	\$38 for 10 people
2C	Fresh fruit and frozen yoghurt energy boost drink	\$35 for 10 people

BREAK PACKAGES

MENU 3 - Sweet and Savoury Break \$60.00 per 10 pax - 20 pieces
A selection of sweet and savoury homemade muffins
Minimum 10 people / Maximum 50 People

MENU 4 - Tea Break \$75.00 per 10 pax - 30 pieces
Sticky fig and ginger loaf
Spiced carrot and walnut cake
Spiced raspberry and almond friands
Minimum 10 people / Maximum 50 People

MENU 5 - Chocoholic Break \$75.00 per 10 pax – 30 pieces
Chocolate cannoli
Chocolate macadamia brownie
Dark choc chip and walnut cookies
Minimum 10 people / Maximum 50 People

MENU 6 - Savoury Break \$60.00 per 10 pax - 20 pieces
Ham and cheese croissants
Tomato and olive calzones
Minimum 10 people / Maximum 50 People

MENU 7 - Ice Cream Break \$48.00 per 10 pax – 12 pieces Served in iced punch bowl
Homemade individual ice-creams
Homemade individual sorbets
Mini magnums
Minimum 10 people / Maximum 50 People
Ice-cream packages with hire of freezer equipment available on request. Please contact Exhibitor Services

MENU #	Individual Ice Creams	Cost
7A	Homemade individual ice-creams	\$40 (10 pax)
7B	Homemade individual sorbets	\$40 (10 pax)
7C	Mini magnums	\$40 (10 pax)
Homemade ice-cream and sorbet flavours are subject to seasonal change. Please contact exhibitor services for most up to date varieties or if you have a specific request		

SANDWICH PACKAGES

MENU 8 - Sandwich Selection (option 1) \$170.00 per 10 pax – 50 pieces
<ul style="list-style-type: none"> • Roasted Sher wagyu beef with gherkins and mayonnaise on sourdough • Pita wrap with chunky hummus, low fat sour cream, fresh coriander, zahtar spice, red onions cucumber and mescaline • Homemade prosciutto on rye bread with smoked cheese and homemade tomato relish
Minimum 10 people / Maximum 50 People

MENU 9 - Sandwich Selection (option 2) \$170.00 per 10 pax – 50 pieces
<ul style="list-style-type: none"> • Double smoked ham with eggplant jam on ciabatta rolls • Chicken Caesar salad in traditionally baked Turkish bread rolls • Char grilled pumpkin, ricotta with fennel on a wholemeal pumpkin seed roll
Minimum 10 people / Maximum 50 People

MENU 10 - Sandwich Selection with Tokyo Rolls \$180.00 per 10 pax – 50 pieces
<ul style="list-style-type: none"> • Whole meal meister roll with avocado, cucumber, tomato, basil, yoghurt dressing, spinach and matured cheddar
<ul style="list-style-type: none"> • Pepper cured ocean trout on mini bagels with red onions and baby capers
<ul style="list-style-type: none"> • Selection of Tokyo rolls with soy sauce
Minimum 10 people / Maximum 50 People

MENU 11 - Sandwich Selection with Rice paper Rolls \$190.00 per 10 pax – 50 pieces
<ul style="list-style-type: none"> • Tandoori chicken pita wrap with cucumber raita
<ul style="list-style-type: none"> • Honey smoked ham in a casalinga baguette with mustard dressing and cheddar
<ul style="list-style-type: none"> • Vegetarian rice paper rolls with nam prik sauce
Minimum 10 people / Maximum 50 People

SOMETHING EXTRA

MENU 12 - Tokyo Rolls with Soy Sauce \$180 per 10 pax - 30 pieces
Tokyo rolls filled with:
<ul style="list-style-type: none"> • Japanese omelette, avocado, mayonnaise
<ul style="list-style-type: none"> • Teriyaki chicken, avocado, red pepper
<ul style="list-style-type: none"> • Crab, cucumber, mayonnaise
<ul style="list-style-type: none"> • Atlantic salmon, cucumber and wasabi
Minimum 10 people / Maximum 50 People

MENU 13 - Vietnamese Rice Paper Rolls with Nam Prik Sauce \$200 per 10 pax - 30 pieces
Vietnamese rice paper rolls filled with:
<ul style="list-style-type: none"> • Peking duck with hoisin
<ul style="list-style-type: none"> • Teriyaki chicken
<ul style="list-style-type: none"> • Prawn and vegetable
<ul style="list-style-type: none"> • Vegetarian with coriander and chilli
Minimum 10 people / Maximum 50 People

MENU 14 - Victorian Cheese Platter \$100 per platter for 10 people
<ul style="list-style-type: none"> A platter of hand selected Victorian cheeses with quince paste. Served with lavoche and water crackers.
Minimum 10 People / Maximum 50 People

MENU 15 - Fruit Platter \$70 per platter for 10 people
<ul style="list-style-type: none"> A platter of fresh local and tropical fruit served with homemade vanilla yoghurt
Minimum 10 People / Maximum 50 People

MENU #	Additional Items	Cost
16	Whole Fruit	\$1.50 per piece
17	A selection of freshly baked cookies: 1kg box \$ 45.00 (30 pieces)	\$45.00
18	A selection of freshly baked cookies: 2kg box (60 pieces)	\$80.00
19	Roasted mixed nuts 1kg bag (served in bowl)	\$18.00
20	Hot mix 1kg (served in bowl)	\$16.50
21	Samboy Chips (plain flavour) 45g (served in bowl)	\$3.00
22	Sorbet and Ice Cream Cart Package <i>Please see next page (section 2.10) for details</i>	\$450.00 per day
23	Additional Tubs of Ice Cream/Sorbet (5 Litres)	\$100
	Ice Cream Cones and Napkins – 60	FOC per Tub
	Ice Cream Cups & Spoons and Napkins - 60	FOC per Tub

NOTE: Lost or damaged crockery will be on charged to the exhibitor.

2.10 SORBET AND ICE CREAM CART PACKAGE

Package includes:

- Hire of cart (cart holds a maximum of 7 tubs at a time)
- 3 x 5 litre tubs of ice cream/sorbet (minimum per day)
- 180 x cones or individual cups and spoons both supplied with napkins. Please specify on the Stand Catering Order Form what you require.

The package cost is \$450.00 per day (inclusive of GST).

To comply with MCEC health and safety standards, an MCEC staff member is required to scoop and serve the ice cream/sorbet. Staff hire rates are as below (inclusive of GST). Please note that a 3.5 hour minimum shift applies.

Monday-Friday	\$39.00
Saturday	\$42.00
Sunday	\$47.00

*Staff hire rates are subject to change without notice.

Additional tubs can be arranged at the cost of \$100.00 each. One 5 litre tub provides approximately 60 serves.

All ice cream and sorbet are made on site at the MCEC and flavours are seasonal. To enquire about the current flavours available, please contact Exhibitor Services (03) 9235 8110. Specific flavours may be available upon request (subject to availability).

ALL ORDERS MUST BE RECEIVED 10 DAYS PRIOR TO THE COMMENCEMENT OF THE EVENT.

Please complete the Exhibitor Services Account Form (2.1) and Stand Catering Order Form (2.8.1).

2.11 STAND CATERING GUIDELINES FOR ORDERING DRINKS

Stand Catering beverage selections are available for your staff during your event. If you wish to entertain guests or serve alcohol on your stand, please discuss your options with your Exhibitor Services Co-ordinator. (03) 9235 8110

Please note that under Victorian State legislation, service of alcohol requires staff with current Victorian Responsible Service of Alcohol certification. The number of service staff required will be determined by the size of your order. Please note that alcohol will not be delivered to your stand prior to staff starting times. (Please see section 2.10 for staff rates)

Exhibitors are not permitted to bring their own water coolers or other drinks.

Alcohol must not be brought into the venue without the prior approval of the Director of Food & Beverage.

No alcohol is to be consumed on the exhibition floor during designated move-in periods and 30 minutes prior to and during move out periods.

All beverages are delivered to your stand cold. It is recommended for large orders of drinks or where exhibitors wish to keep beverage orders cold for long periods of time that a fridge is ordered for your stand. MCEC does not hire out fridges so any fridge requirements will need to be ordered through your stand builder or external exhibition hire company.

If you have not arranged a fridge for your stand you have the option of hiring a punch bowl. Please note punch bowls hold minimal beverages – maximum of 24 x soft drinks/juice. With each punch bowl hire for your drinks you will receive complementary ice with the initial delivery however if your punch bowl needs replenishing throughout the day you will be required to order bags of ice at additional costs.

2.11.1 STAND BEVERAGE SELECTION

Item Code	Beverage Item	Size	Cost
A	Twelve (12) Still Water	400ml	\$32.00
B	Twelve (12) Plain Mineral Water	300ml	\$36.00
C	Twelve (12) Assorted Soft Drinks – 5 flavours <i>Coke, Diet Coke, Sprite, Lift, Fanta</i> (please specify if anything in particular is required)	390ml	\$36.00
D	Twelve (12) Assorted Juice – 4 flavours <i>Orange or Apple or Apple & Blackcurrant or Apple Mango & Banana</i> (please specify if anything in particular is required)	350ml	\$36.00
E	Twelve (12) Assorted Mineral Water – 3 flavours <i>Orange & Passionfruit or Lemon Lime & Orange or Plain</i> (please specify if anything in particular is required)	300ml	\$36.00
F	Six (6) Energy Drinks - Mother	500ml	\$27.00
NB Bottle openers will be automatically added to any beer orders. A \$10 deposit is required, fully refundable upon return to the Food & Beverage Department			
G	Six (6) Grand Ridge Brewers Pilsener	330ml	\$36.00
H	Six (6) Grand Ridge Draught Bitter	330ml	\$36.00
I	Six (6) Grand Ridge Almighty Light	375ml	\$33.00
J	Six (6) Boag's Draught	375ml	\$37.50
K	Six (6) Boag's Premium Light	375ml	\$34.50
Prices are available on request for other Grand Ridge, Becks and Heineken beers			
L	Sparkling Wine De Bortoli Rococo Blanc de Blanc 5 champagne flutes per bottle are supplied FOC (hire) up to a maximum of 30 glasses (Additional glasses above the maximum allowed will be automatically charged at \$1.10 per glass) **Enter on order form how many champagne flute glasses required	750ml	\$35.00

Item Code	Beverage Item	Size	Cost
M	<p>BOTTLES OF WINE <i>Please specify on order form what wines and quantities of each are required</i></p> <p>White Wine – Please select from the following: Chardonnay Sauvignon Blanc Riesling</p> <p>Red Wine - Please select from the following: Shiraz Cabernet Pinot Noir</p> <p>5 wine glasses per bottle are supplied FOC (hire) up to a maximum of 30 glasses <i>(Additional glasses above the maximum allowed will be automatically charged at \$1.10 per glass)</i></p> <p>**Enter on order form how many wine glasses required</p>	750ml	\$32.00 per Bottle
Prices are available on request for other items such as Champagne			
Item Code	Additional Items	Cost	
N	Water Cooler Unit (supplied for duration of event)	\$115.50	
O	15 Litre Water Bottle	\$24.00	
P	Water Cooler Cups (Pkt of 100)	\$12.50	
Q	Clear Plastic Cups 425ml (Pkt of 50)	\$9.00	
R	Bag Of Ice	\$5.50	
S	Punch Bowl Hire (per bowl)	\$10.00	
T	Wine Glass Hire (per glass)	\$1.10	
U	Champagne Flutes Hire (per glass)	\$1.10	
V	Beer Glass Hire (per glass)	\$1.10	
W	Highball Glass Hire (per glass)	\$1.10	

2.11.2 MCEC SPECIALTY BEER & SPARKLING WINE

The MCEC is proud to offer outstanding products from two of our key beverage partners, Grand Ridge Brewery and De Bortoli Winery. These excellent Victorian products reflect the high quality of food and beverage available within the MCEC.

Grand Ridge Beer

Grand Ridge Brewers Pilsener and Grand Ridge Draught Bitter are both produced at the boutique Grand Ridge Brewery in Mirboo North, 75 minutes east of Melbourne's CBD. Both beers are made without chemicals and come from the world's most awarded brewery.



Brewers Pilsener

The Brewers Pilsener is a European-style lager and is crisp and refreshing, appealing to everyone.



Draught Bitter

The Draught Bitter is a more Australian-style lager with a big flavour, designed to suit traditional Australian beer drinkers. Originally brewed for the MCEC, this is now on commercial release to the public as well.

De Bortoli's Rococo Blanc de Blanc Sparkling Wine



De Bortoli's Rococo Blanc de Blanc is a sparkling wine produced and made from grapes grown in the Yarra Valley. This special sparkling is pale yellow, has a persistent bead and has classical Champagne-style aromas and flavours such as green apples, flowers, citrus and toast. It tastes soft and creamy with an acidity that leaves a clean dry finish. A perfect aperitif or afternoon drink.



2.14 FOOD AND BEVERAGE OUTLET ACCOUNT CARD ORDER FORM

Please indicate your requirements below and return together with the Exhibitor Services Account form to fax number +61 3 9235 8121.

Exhibitor Services Account Form has been attached

Order cannot be processed without the completed details below and the Exhibitor Services Account Form.

The following Food and Beverage Outlets are available at the MCEC:

- Kiosks
- M Café
- Exhibitor Lounge
- Coffee Cart

Exhibitors at the Melbourne Exhibition Centre wishing to purchase food and beverage from the M Café, Kiosk and / or the Exhibitor Lounge may charge their purchases to an Account Card. To arrange a Food and Beverage Outlet Account Card simply complete the details below together with the Exhibitor Services Account Form. Once your Account Card order has been processed a tax invoice and payment form will be issued from Exhibitor Services. Amounts due to be refunded will be confirmed when all final invoices are distributed after the conclusion of the event.

Once your nominated credit limit has been reached, your authorisation to increase the credit will be required before further food and beverage purchases may be charged.

Please Note: Please retain all receipts as charges are not itemised. GST is charged at the point of sale – please retain all receipts for details of GST incurred.

Credit limit required:	\$
Number of cards required:	
Account cards are required to be collected at Customer Service desk on:	/ /
Office Use Only - Account Card Number:	#