

### CONTACT DETAILS:

Company Name:	
Address:	
State:	Postcode:
Contact Name:	
Telephone:	Facsimile:
Mobile:	
Email:	1111

### STAND DETAILS:

Exhibition/Conference: ISMRM 2012	
Start Date: 06/05/12	Finish Date: 10/05/12
Venue: MCEC	
Stand No:	
Stand Name:	

Please illustrate in the diagram below the position of the banner & direction the signage is to face.

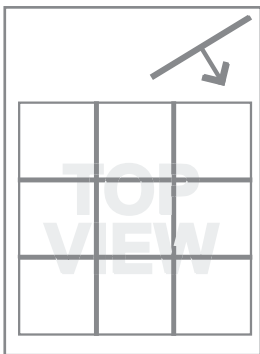

FRONT OF STAND

#### BANNER DIMENSIONS

Length: .....m  
Width: .....m  
Weight:.....kg

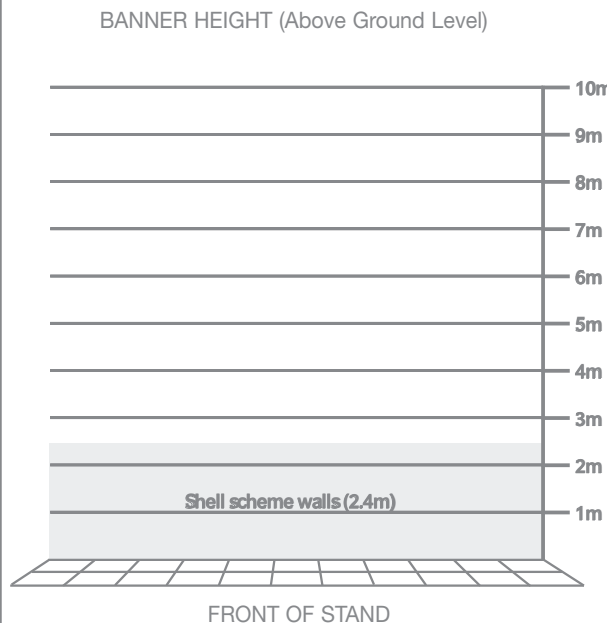

### TICK BOX & COMPLETE FORM FOR A QUOTATION

Banner Suspension

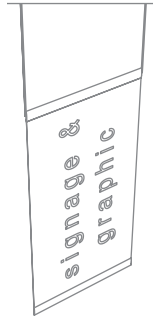

Truss & 1500wt QI Flood Lights or 400wt Metal Halide Flood Lights

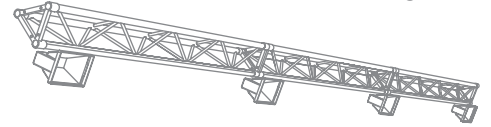

Truss & 1000wt Flood Lights

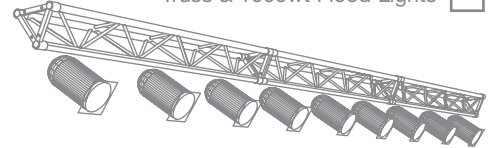

Banner, Truss & 300wt Arm Lights

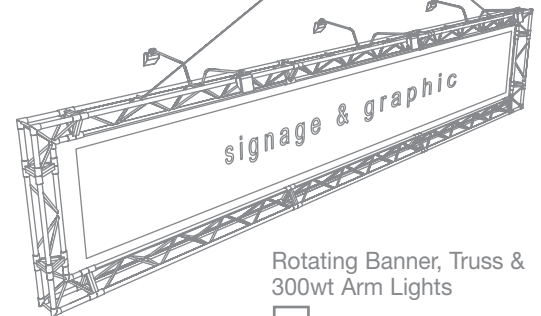
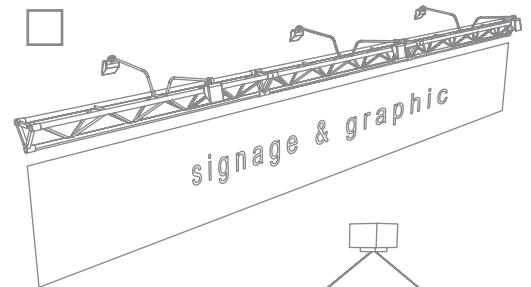

Rotating Banner, Truss & 300wt Arm Lights

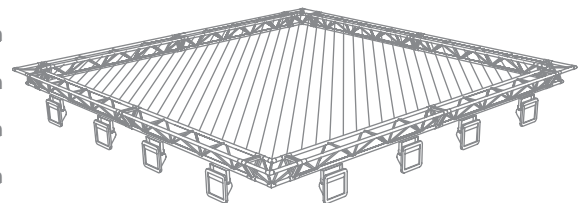

Truss & Fabric (wide range of colours available) 400wt Metal Halide Flood Lights

### TERMS & CONDITIONS:

All banners must be delivered to Harry the Hirer no later than seven working days prior to installation. Please note any banner received after this date is subject to a 20% rigging surcharge. Harry the Hirer accepts no responsibility or cost incurred in the delivery & return of banners supplied. A charge of \$55.00 will apply to every banner that is supplied without suspension rods (if required). Please note all banners are required to have clearly marked exhibitor stand details & contact number. All banners are to be collected from site during move-out. Banners & Trussing final locations are subject to available suspension points at time of installation. Harry the Hirer will endeavour to collect any remaining banners from the site, but accepts no responsibility for the loss or damage of them from this time onwards.